

SOFIA PROFESSIONAL 30"



CODE ID

30" PROFESSIONAL DOUBLE OVEN - STAINLESS STEEL

F6PDP30S1



- Dual Convection
- Soft Closing Door
- Self Clean Ovens
- Multi-level cooking
- 1 Telescopic Rack per oven
- Cool Touch Door
- Digital Controls
- Meat Probe (Upper Oven Only)
- Fast Pre-Heat
- Interior Lighting

COLOR KIT

	STAINLESS STEEL	
	MATTE BLACK	RAL 9004
	GLOSSY BLACK	RAL 9004
	GLOSSY RED	RAL 3003
	GLOSSY WHITE	RAL 9016
	MATTE GREY	RAL 9007
	MATTE WHITE	RAL 9016

OVENS

Knob and electronic controls
Dual True Convection
Self-cleaning oven with Multifunction baking
Black Porcelain enamel interior
Cool to the touch, soft closing door
Extra-large baking cavity and viewing area
3 Halogen lights for flawless visibility
Gross capacity 4.4 cu. ft. per oven
2 chromed racks
1 telescopic rack per oven
Enameled Broiler Pan

OVEN FUNCTIONS

Bake
Broil
Roast
Convection
True Convection
Warm / Proof / Dehydrate
Electronic cooking programmer
Meat Probe (Upper Oven Only)
Self-Clean
Sabbath Mode

OPTIONAL ACCESSORIES

PODKIT30 ... Colour kit upper door
PDRKIT30 ... Colour kit lower door

NOTE:

For colour kit purchase order, remember to order both colour kits for the upper and lower door.

FMTRP36 Telescopic rack

SOFIA

30" PROFESSIONAL OVEN

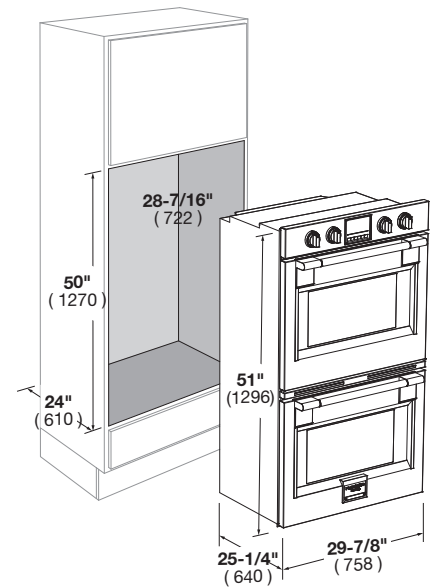

CODE ID	F6PDP30S1 - 30" PROFESSIONAL DOUBLE OVEN	
Series and Finish	600 Series - Professional Design - Stainless Steel	
CONTROL PANEL		
Control Type	2 Heavy Duty Knobs	
Oven Programming	Electronic with 6 Touch Keys	
Display: Clock - Temperature - Timer	White LED	
Language	English	
OVEN		
Type	Dual True Convection	
Temperature Regulation	Electronic Control (min/max 170/550°F - 75/290°C)	
OVEN FUNCTIONS		
	Pyrolytic Self-Clean	Broil
	True Convection	Dehydrate
	Convection Bake	Thaw (Defrost)
	Convection Broil	Proof (Warm)
	Convection Roast	Keep warm (Warm Plus)
	Pizza (Lower Convection)	Oven Lights
	Bake	
ELECTRIC OVEN FEATURES		
	Preset/Last Used Temperature Memory	Preheat Indicator (25%, 50%, 75%, 100%)
	Control Display Lock	Sabbath Mode
	Child Door Lock	Temperature Display °C/°F
	Meat Probe (Upper Oven Only)	
OVEN DOOR(S)		
Oven Glass Window	Large See Through Glass	
Door Cooling System	4 Heat Resistant Glasses	
Door Hinges - Soft-closing System	Heavy Duty Steady Tilt	
Handle Style	Tubular Steel	
OVEN CAVITY		
Gross Capacity (cbft)	4.4	
Usable Capacity (cbft)	4.1	
Cavity Enamel Colour	Black	
Rack Positions	6	
Oven Lights	3x20W Halogen	
HEATING ELEMENTS (@240V)		
Broil Upper Heating Element	3500 W	
Upper Auxiliary Element	1032 W	
Concealed Bake Lower Heating Element	3000 W	
Convection Element	2 x 1300 W	
OVEN ACCESSORIES		
Chromed Racks	2 on both ovens	
Enameled Broiler Pan (basin + anti splash)	1 on both ovens	
Telescopic Chromed Rack	1 on both ovens	
DIMENSIONS/WEIGHT		
Overall dim - Width	29 - 11/16"	(754 mm)
Overall dim - Height	51"	(1295 mm)
Overall dim - Depth	24"	(610 mm)
Cut-out - Width	28 - 7/16"	(722 mm)
Cut-out - Height (min)	50"	(1270 mm)
Cut-out - Depth (min)	23 - 1/4"	(590 mm)
Gross Weight	340 lbs	(154 kg)
POWER / RATINGS (208/240 V, 60 HZ)		
kW / Amps rating at 240V, 60Hz	7.68 kW - 33.8A	
kW / Amps rating at 208V, 60Hz	6.48 kW - 32.4A	
Power Cable	Conduit	
INSTRUCTIONS FOR USE		
Use & Care Manual / Installation Manual	English / French / Spanish	