





24" WARMING DRAWER

MATTEO 400 SERIES

MODEL CODE

F4MWD24S1



-  Keep Warm
-  Defrost
-  Proofing
-  Push Opening
-  Slow Cooking
-  Sliding Telescopic Rails
-  Fingerprint-resistant Stainless Steel
-  Americans with Disabilities Act †

DESCRIPTION

The Matteo 400 series push-to-open compact warming drawer, finished in fingerprint-resistant stainless steel, is the perfect addition to any kitchen, offering seamless integration with your existing appliances. Designed for flexibility, it pairs beautifully with the Matteo "compact wall oven column" when stacking other 24" built-in appliances. Alternatively, it can be installed beneath a matching built-in coffee machine to keep cups warm or positioned below a combi speed oven or combi steam oven. With its 24" x 24" footprint, this warming drawer is functional while optimizing space for a sleek, modern kitchen setup.

FEATURES

Knob Control
 Push latch system to open and close the drawer
 Heavy Duty full extension rails
 True convection or Fan assisted heating system
 Even heat distribution
 All stainless steel structure
 Warming Temperature range: min. 90 °F up to 160 °F
 (min. 30 °C up to 70 °C)

FUNCTIONS

Pre-heat dishes
 Pre-heat coffee cups
 Keep warm ready food
 Defrosting
 Leavening dough
 Slow cooking min. 90 °F up to 160 °F
 (min. 30 °C up to 70 °C)

† To achieve full ADA compliance, please consult the current ADA requirements for product installation instructions.

24" WARMING DRAWER

MATTEO 400 SERIES

MODEL CODE

F4MWD24S1

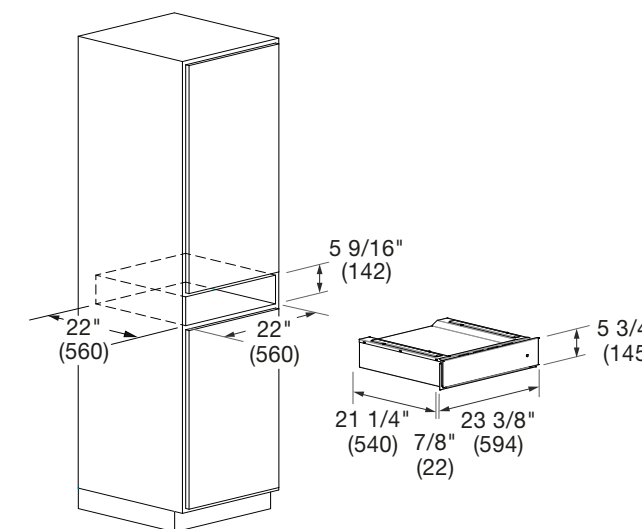

| MODEL CODE | 24" WARMING DRAWER F4MWD24S1 | |
|---|---|-----------|
| GENERAL DETAILS | | |
| Finish | Stainless Steel | |
| Control Type | Electronic Knob | |
| Compatible Ovens | F7MSP24S1 - F7MSM24S1 - F7MSCO24S1 - F7MSPD24S1 | |
| Temperature (max), °F (°C) | 160 | (70) |
| Thermostat, °F (°C) | 90 - 160 | (30 - 70) |
| CAPACITY | | |
| Volume (each), cu. ft. (L) | 0.53 | (15) |
| Useable Width, in. (mm) | 16-1/2 | (420) |
| Useable Height, in. (mm) | 3 | (75) |
| Useable Depth, in. (mm) | 18-7/8 | (480) |
| DIMENSIONS / WEIGHT | | |
| Product Width, in. (mm) | 23-3/8 | (594) |
| Product Height, in. (mm) | 5-3/4 | (145) |
| Product Depth, in. (mm) | 21-1/4 | (540) |
| Cutout Width, in. (mm) | 22 | (560) |
| Cutout Height (min), in. (mm) | 5-9/16 | (142) |
| Cutout Depth (min), in. (mm) | 22 | (560) |
| Net Weight, lbs. (kg) | 29 | (13) |
| POWER / RATINGS | | |
| Max power absorbed (W) | 400 W | |
| Power V (Hz) | 120 | (60) |
| Power Cable | NEMA 5-15P | |
| Power Cable Length, in. (mm) | 53 1/8 | (1350) |
| INSTRUCTIONS FOR USE | | |
| Use & Care Manual / Installation Manual | English / French / Spanish | |
| WARRANTY | | |
| Limited Warranty | Parts and Labor (2-year) | |