

24" COFFEE MACHINE

MATTEO 700 SERIES

MODEL CODE

F7MBC24MB1



On-demand Hot Water



Bean Hopper - Adjustable Grinder



Cappuccino/Latte Maker



LED Lighting



Americans with Disabilities Act †

DESCRIPTION

The Matteo 700 Series 24" built-in coffee machine, featuring our exclusive matte black finish, blends style, performance, and Italian craftsmanship, making it an ideal addition to any premium kitchen. Imagine starting your day with a freshly ground espresso, a rich Americano, or a creamy cappuccino—this fully automatic coffee system brings the true Italian coffee experience to your home. Easy to use and maintain, it offers customizable presets so you can tailor each cup to your personal taste. With a front-accessible water tank and waste compartment, upkeep is effortless, and every unit includes a milk frothing canister for that perfect finish.

FEATURES

- 3 Temperature Settings
- 5 Customizable Coffee Strength Settings: extra-strong, strong, medium, mild, extra-mild
- 5 Customizable Cup Size Settings: espresso, small, medium, large, mug
- Stand-by (energy saving)
- Water Hardness Setting
- Coffee and Water Refill Indicators
- Empty Waste Container Indicator
- Cleaning Indicator
- Descale Indicator

FUNCTIONS

- Espresso / Double Espresso
- Coffee / Double Coffee
- Latte
- Cappuccino
- Milk froth
- Warm milk
- Hot water
- Steam
- Water heating time: 1 minute
- Automatic rinsing cycle

INCLUDED ACCESSORIES

1C0000197	Frother for Milk
1C0000198	Container for Milk
1C0000254	Right Guide for Telescopic Rails
1C0000253	Left Guide for Telescopic Rails
1C0000218	Power Cord with Plug

† To achieve full ADA compliance, please consult the current ADA requirements for product installation instructions.

24" COFFEE MACHINE

MODEL CODE

MATTEO 700 SERIES

F7MBC24MB1

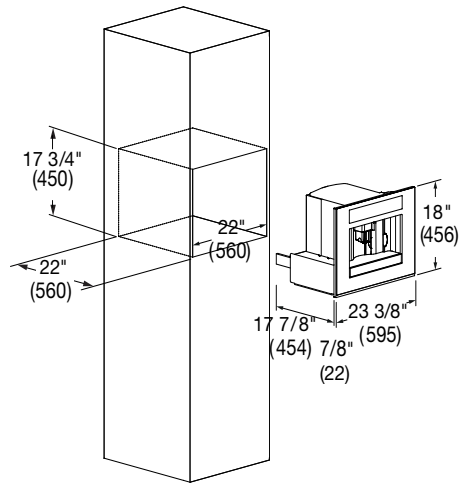

MODEL CODE	24" COFFEE MACHINE F7MBC24MB1	
GENERAL DETAILS		
Finish	Matte Black	
Control Type	Electronic Touch Control	
Language	19 including: English (USA) / English (UK) / French / Spanish	
FEATURES		
Total number of modes	30	
Automatic modes	Coffee, Steam, Hot water	
Cups of coffee dispensed at a time	1 or 2	
Adjustable grinder	13 settings	
Maximum cup height in. (mm)	3 7/8 (100)	
Dispenser for steam and hot water	Yes	
LED lighting	2	
Auto wakeup	Yes	
Auto shutoff	Yes	
Drip tray	Removable	
Fill Water Tank Warning	Yes	
CAPACITY		
Water tank capacity, fl.oz (L)	60 (1.8)	
Bean hopper capacity, oz (g)	7 (200)	
DIMENSIONS / WEIGHT		
Product Width, in. (mm)	23-3/8 (595)	
Product Height, in. (mm)	18 (456)	
Product Depth, in. (mm)	17-7/8 (454)	
Cutout Width, in. (mm)	22 (560)	
Cutout Height (min), in. (mm)	17-3/4 (450)	
Cutout Depth (min), in. (mm)	22 (560)	
Recess (WxHxD), in. (mm)	22 x 17-3/4 x 22 (560 x 450 x 560)	
Net Weight, lbs. (kg)	66 (30)	
POWER / RATINGS (120V, 60HZ)		
Max rated power (W)	1350 W (120 V)	
Pump pressure (bar)	15	
INSTRUCTIONS FOR USE		
Use & Care Manual / Installation Manual	English / French / Spanish	