

# 30" MULTIFUNCTION EASY-CLEAN OVEN



MODEL CODE

MATTEO 100 SERIES

**F1MSM30S1**



True Convection



Multi-level Cooking



Cool Touch Door



Interior Lighting



Fingerprint-proof Stainless Steel



Digital Controls



Americans with Disabilities Act †

## DESCRIPTION

The Matteo 100 Series 30" oven combines full-size performance with a sleek, compact design, ideal for modern kitchens. Its fingerprint-resistant stainless finish and 24" height make it perfect for ADA-compliant installations or space-conscious designs. This single oven features a cool-touch door for safety, easy cleaning, a multi-pass broiler, and true convection for even results. Concealed bake elements provide a streamlined look, and seven intuitive baking functions ensure ease of use. A reliable, flexible addition to any kitchen, the 100 Series elevates both style and functionality.

## FEATURES

- Knob and electronic controls
- Black Porcelain enamel interior
- 2 Halogen lights
- Cool to the touch
- 2 Chromed racks
- Enameled Broiler pan

## FUNCTIONS

- Broil
- Eco Broil
- Convection Broil
- True Convection
- Convection Roast
- Bake
- Defrost

## INCLUDED ACCESSORIES

2 x 12200240	Chromed rack
42105321	Enameled Broiler pan

## OPTIONAL ACCESSORIES

TELG60M	Telescopic Rack
---------	-----------------

† To achieve full ADA compliance, please consult the current ADA requirements for product installation instructions.

# 30" MULTIFUNCTION EASY-CLEAN OVEN



MODEL CODE

MATTEO 100 SERIES

**F1MSM30S1**

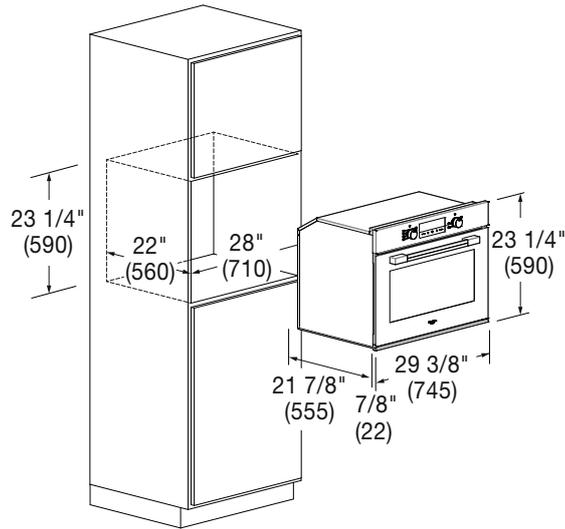

MODEL CODE	30" MULTIFUNCTION EASY-CLEAN OVEN F1MSM30S1	
<b>GENERAL DETAILS</b>		
Finish	Stainless Steel	
Control Type	2 Knobs / 3 Touch Buttons	
Display	White LED	
Oven Type	Convection	
Temperature (min - max), °F (°C)	120 - 540 (50 - 285)	
Rack Positions	5	
Interior Lights	2 x 25 W Halogen	
<b>CAPACITY</b>		
Volume, cu. ft. (L)	3.2	(86)
Useable Width, in. (mm)	22-13/16	(580)
Useable Height, in. (mm)	13-3/4	(350)
Useable Depth, in. (mm)	16-9/16	(420)
<b>DIMENSIONS / WEIGHT</b>		
Product Width, in. (mm)	29-3/8	(745)
Product Height, in. (mm)	23-1/4	(590)
Product Depth, in. (mm)	21-7/8	(555)
Cutout Width, in. (mm)	28	(710)
Cutout Height (min), in. (mm)	23-1/4	(590)
Cutout Depth (min), in. (mm)	22	(560)
Net Weight, lbs. (kg)	111	(50)
<b>POWER / RATINGS (240 V, 60 Hz)</b>		
Broil Upper Heating Element	1200 W	
Upper Auxiliary Element	1200 W	
Concealed Lower Bake Element	1360 W	
Convection Element	2300 W	
<b>TECHNICAL DETAILS</b>		
kW / Amps rating at 120-240 V, 60 Hz	2.65kW - 11.0A	
kW / Amps rating at 120-208 V, 60 Hz	2.00kW - 9.6A	
Power Cable	4-Wire Conduit – Hardwire Connection	
Power Cable Length, in. (mm)	56	(1422)
Electrical Circuit	240 / 208 V - 60 Hz - 15 A	
<b>INSTRUCTIONS FOR USE</b>		
Use & Care Manual / Installation Manual	English / French / Spanish	
<b>WARRANTY</b>		
Limited Warranty	Parts and Labor (2-year)	