

30" SELF-CLEAN OVEN



MODEL CODE

MATTEO 100 SERIES

F1MSP30S1



True Convection



Self-Clean Oven



Multi-Level Cooking



Cool Touch Door



Interior Lighting



Digital Controls



Fingerprint-proof Stainless Steel



Americans with Disabilities Act †

DESCRIPTION

The Matteo 100 Series 30" oven combines full-size performance with a sleek, compact design, making it an ideal choice for modern kitchens. Its fingerprint-resistant stainless finish and 24" height make it perfect for ADA-compliant installations or space-conscious designs, such as multi-family high-rises. Packed with features including a cool-touch door for safety, a self-cleaning function, a multi-pass broiler, and true convection for even results. Concealed bake elements offer a streamlined look and simplify cleaning. Eight intuitive baking functions provide easy control, making it a versatile, reliable addition to any kitchen.

FEATURES

- Knob and electronic controls
- Single fan true convection
- Self-cleaning oven with Multifunction baking
- Electronic cooking programmer
- Black Porcelain enamel interior
- Cool to the touch
- Extra-large baking cavity and viewing area
- 2 Halogen lights for flawless visibility
- 2 Chromed racks
- Enameled Broiler pan

FUNCTIONS

- Self-Clean
- Broil
- Convection Broil
- True Convection
- Convection Roast
- Bake
- Defrost
- Sabbath Mode

INCLUDED ACCESSORIES

2 x 12200240	Chromed rack
42105327	Enameled Broiler pan

OPTIONAL ACCESSORIES

TELG60M	Telescopic Rack
---------	-----------------

† To achieve full ADA compliance, please consult the current ADA requirements for product installation instructions.

30" SELF-CLEAN OVEN



MODEL CODE

MATTEO 100 SERIES

F1MSP30S1

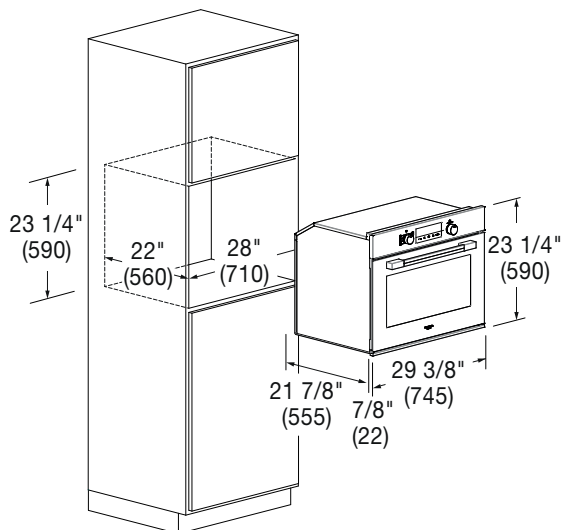

MODEL CODE	30" SELF-CLEAN OVEN F1MSP30S1	
GENERAL DETAILS		
Finish	Stainless Steel	
Control Type	Dual Knob	
Display	White LED	
Oven Type	True Convection	
Temperature (min - max), °F (°C)	120 - 485	(50 - 250)
Rack Positions	5	
Interior Lights	2 x 25 W Halogen	
CAPACITY		
Volume, cu. ft. (L)	3.2	(86)
Useable Width, in. (mm)	22-13/16	(580)
Useable Height, in. (mm)	13-3/4	(350)
Useable Depth, in. (mm)	16-9/16	(420)
DIMENSIONS / WEIGHT		
Product Width, in. (mm)	29-3/8	(745)
Product Height, in. (mm)	23-1/4	(590)
Product Depth, in. (mm)	21-7/8	(555)
Cutout Width, in. (mm)	28	(710)
Cutout Height (min), in. (mm)	23-1/4	(590)
Cutout Depth (min), in. (mm)	22	(560)
Net Weight, lbs. (kg)	128	(58)
POWER / RATINGS (240 V, 60 Hz)		
Broil Upper Heating Element	1200 W	
Upper Auxiliary Element	1200 W	
Concealed Lower Bake Element	1360 W	
Convection Element	2300 W	
TECHNICAL DETAILS		
kW / Amps rating at 120-240 V, 60 Hz	3.8 kW - 15.8 A	
kW / Amps rating at 120-208 V, 60 Hz	2.9 kW - 14.0 A	
Power Cable	4-Wire Conduit – Hardwire Connection	
Power Cable Length, in. (mm)	56	(1422)
Electrical Circuit	240 / 208 V - 60 Hz - 20 A	
INSTRUCTIONS FOR USE		
Use & Care Manual / Installation Manual	English / French / Spanish	
WARRANTY		
Limited Warranty	Parts and Labor (2-year)	