

30" COFFEE MACHINE

MATTEO 700 SERIES



MODEL CODE

F7MTK30BCS + F7BC24B1

-  On-demand Hot Water
-  Bean Hopper - Adjustable Grinder
-  Cappuccino/Latte Maker
-  LED Lighting
-  Americans with Disabilities Act †

DESCRIPTION

The Matteo 700 Series 30" built-in coffee machine trim kit, featuring a fingerprint-resistant stainless finish, offers a sleek and customizable solution for seamlessly integrating the F7BC24B1 automatic coffee machine base unit with your kitchen. When installed in a stacked column, it blends effortlessly with other 30" Matteo built-in ovens and specialty ovens, creating a cohesive, sophisticated look. The F7BC24B1 base unit, sold separately, is designed to pair with the F7MTK30BCS Matteo 30" trim kit.

FEATURES

- 3 Temperature Settings
- 5 Customizable Coffee Strength Settings: extra-strong, strong, medium, mild, extra-mild
- 5 Customizable Cup Size Settings: espresso, small, medium, large, mug
- Stand-by (energy saving)
- Water Hardness Setting
- Coffee and Water Refill Indicators
- Empty Waste Container Indicator
- Cleaning Indicator
- Descale Indicator

FUNCTIONS

- Espresso / Double Espresso
- Coffee / Double Coffee
- Latte
- Cappuccino
- Milk froth
- Warm milk
- Hot water
- Steam
- Water heating time: 1 minute
- Automatic rinsing cycle

INCLUDED ACCESSORIES

- 1C0000197 Frother for Milk
- 1C0000198 Container for Milk
- 1C0000254 Right Guide for Telescopic Rails
- 1C0000253 Left Guide for Telescopic Rails
- 1C0000218 Power Cord with Plug

† To achieve full ADA compliance, please consult the current ADA requirements for product installation instructions.

30" COFFEE MACHINE

MATTEO 700 SERIES



MODEL CODE

F7MTK30BCS + F7BC24B1

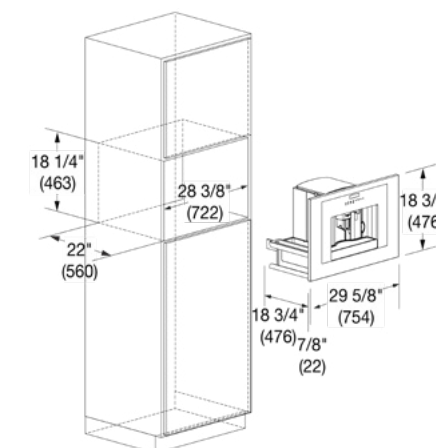

MODEL CODE	30" COFFEE MACHINE F7MTK30BCS + F7BC24B1	
GENERAL DETAILS		
Finish	Stainless Steel	
Control Type	Electronic Touch Control	
Language	19 including: English (USA) / English (UK) / French / Spanish	
FEATURES		
Total number of modes	30	
Automatic modes	Coffee, Steam, Hot water	
Cups of coffee dispensed at a time	1 or 2	
Adjustable grinder	13 settings	
Maximum cup height in. (mm)	3 7/8	(100)
Dispenser for steam and hot water	Yes	
LED lighting	2	
Auto wakeup	Yes	
Auto shutoff	Yes	
Drip tray	Removable	
Fill Water Tank Warning	Yes	
CAPACITY		
Water tank capacity, fl.oz (L)	60	(1.8)
Bean hopper capacity, oz (g)	7	(200)
DIMENSIONS / WEIGHT		
Product Width, in. (mm)	29 - 5/8	(754)
Product Height, in. (mm)	18 3/4	(476)
Product Depth, in. (mm)	18 - 3/4	(476)
Cutout Width, in. (mm)	28 3/8	(722)
Cutout Height (min), in. (mm)	18 - 1/4	(463)
Cutout Depth (min), in. (mm)	22	(560)
Recess (WxHxD), in. (mm)	28-3/8" x 18-1/4" x 22	(722 x 463 x 560)
Net Weight, lbs. (kg)	66	(30)
POWER / RATINGS (120V, 60HZ)		
Max rated power (W)	1350 W	(120 V)
Pump pressure (bar)	15	
INSTRUCTIONS FOR USE		
Use & Care Manual / Installation Manual	English / French / Spanish	