



Fully Integrated 60

FDW 82914 PB



- Electronic push-buttons
- 14 places settings
- 9 program
- 3 racks
- Antibacterial Filter
- Child Lock
- Bottle holder
- Infoled and interior light
- Noise level 49 dbA
- Energy class A

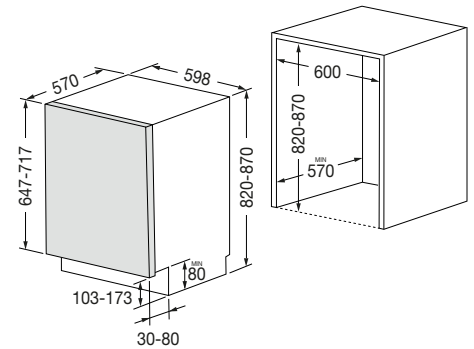

Features

This dishwasher in “A” class, combines technology and in the meantime easy management and energy saving. 3 racks levels, half-load for all programs. The control panel allows to the users to select the washing program very easily and warns them when salt and rinse aid are running out. Sound emission of 49 dB (A); the inverter motor allows to adjust the speed and energy consumption according selected program. Electricity consumption of 292 Kwh. The ECO option reduces energy consumption. Delayed start from 0 to 19 hours. The safety devices include AcquaStop, level sensors, seals against water leaks, child lock, Antibacterial filter, Machine Clean Programme.



INTEGRATED 60
FDW 82914 PB
EAN 8019801034598

DISHWASHING

DISHWASHER



FDW 82914 PB	
Type	Fully integrated
ENERGY CONSUMPTION	
Efficiency class	A
Inverter Motor	•
Electrical diverter	•
Water consumption (litre / cycle)	9 L
Estimated annual energy consumption (Kwh)	292
Estimated annual water consumption (litres)	2.520 lt
Sound level dB (A)	49
MAIN FEATURES	
Max places setting nr.	14
Electronic buttons	•
Interior light	•
Delayed start	•
Door opening system (Autodoor)	•
End of cycle detection floor light/buzzer	•
Drying with door auto-opening	•
Cold/hot water supply (max 60°C)	•
FUNCTIONS AND PERFORMANCE	
Washing programs no.	9
Fast cycles / Auto 45 - 65° C	• / •
Half load (for all programs)	•
Super 50-65°C	•
Drying system	With residual heat
SAFETY SYSTEM	
Water safety	•
Salt indicator /rinse aid indicator	•
Child lock	•
Antibacterial filter	•
Water softener adjustable program	•
Machine clean programme	•
POWER RATING	
Voltage / Frequency (V - Hz)	220 - 240 / 50
Power cord (m) / Plug	1.4 / •
DIMENSIONS, INSTALLATION AND PACKAGING	
Product Height (mm.)	820-870
Product Width (mm.)	598
Product Depth (mm.)	570
Built-in Cut out (W x H xD) mm.	600 x 820-870 x 600
Door height (mm.)	647-717
Gross weight (Kg)	39,5
External packaging type	Cardboardbox
Packaging dimensions : H X W X D	856 x 660 x 675