

Premium - Fully Integrated 60

FDW 82914 TC

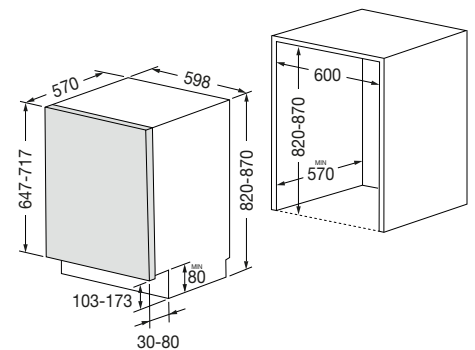

- Touch Control
- 14 places settings
- 9 program
- 3 racks
- Antibacterial Filter
- Child Lock
- Soft touch mug shelf + Bottle holder
- Internal sprayer made in stainless steel
- Infoled and interior light
- Noise level 42 dB (A)
- Energy class A



Features

This dishwasher in "A" class, combines the most high technology and performances in terms of energy saving, noise level and efficiency. 3 racks levels, half-load for all programs. The touch control panel allows to the users to select the washing program very easily and warns them when salt and rinse aid are running out. Sound emission of 42 dB (A) ; the inverter motor allows to adjust the speed and energy consumption according selected program. Electricity consumption of 292 Kwh. Delayed start from 0 to 19 hours. The safety devices include AcquaStop, level sensors, seals against water leaks, child lock, Antibacterial filter, Machine Clean Programme. This dishwasher is also equipped with an innovative "Soft Touch" support that protects glasses from scratches and damages, reducing noise and vibrations during operation.



INTEGRATED 60
FDW 82914 TC
EAN 8019801034574

DISHWASHING

DISHWASHER

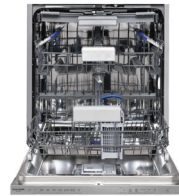

FDW 82914 TC	
Type	Fully integrated
ENERGY CONSUMPTION	
Efficiency class	A
Inverter Motor	•
Electrical diverter	•
Water consumption (litre / cycle)	9 L
Estimated annual energy consumption (Kwh)	292
Estimated annual water consumption (litres)	2.520 lt
Sound level dB (A)	42
MAIN FEATURES	
Max places setting nr.	14
Touch controls	•
Interior light	•
Delayed start	•
Door opening system (Autodoor)	•
End of cycle detection floor light/buzzer	•
Drying with door auto-opening	•
Cold/hot water supply (max 60°C)	•
FUNCTIONS AND PERFORMANCE	
Washing programs no.	9
Fast cycles / Auto 45 - 65° C	• / •
Half load (for all programs)	•
Super 50-65°C	•
Drying system	With residual heat
SAFETY SYSTEM	
Water safety	•
Salt indicator /rinse aid indicator	•
Child lock	•
Antibacterial filter	•
Water softener adjustable program	•
Machine clean programme	•
POWER RATING	
Voltage / Frequency (V - Hz)	220 - 240 / 50
Power cord (m) / Plug	1.4 / •
DIMENSIONS, INSTALLATION AND PACKAGING	
Product Height (mm.)	820-870
Product Width (mm.)	598
Product Depth (mm.)	570
Built-in Cut out (W x H xD) mm.	600 x 820-870 x 600
Gross weight (Kg)	39,5
External packaging type	Cardboardbox
Packaging dimensions : H X W X D	856 x 660 x 675