

FULGOR

MILANO

SOFIA

ENDLESS PASSION FOR COOKING

FSRC 3004 P MI MK 2F * / FSRC 9005 P MI MK 2F *



INSTRUCTION MANUAL

Dear Customer,

Thank you for purchasing one of our Sofia ranges. This range was conceived, designed and handcrafted in Italy.

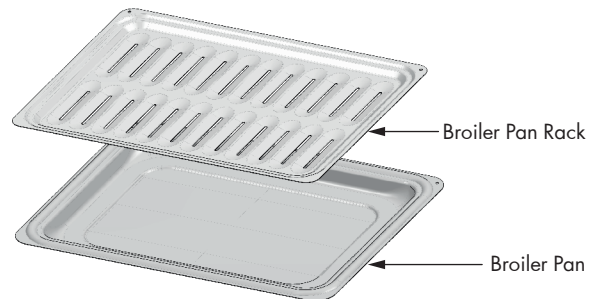
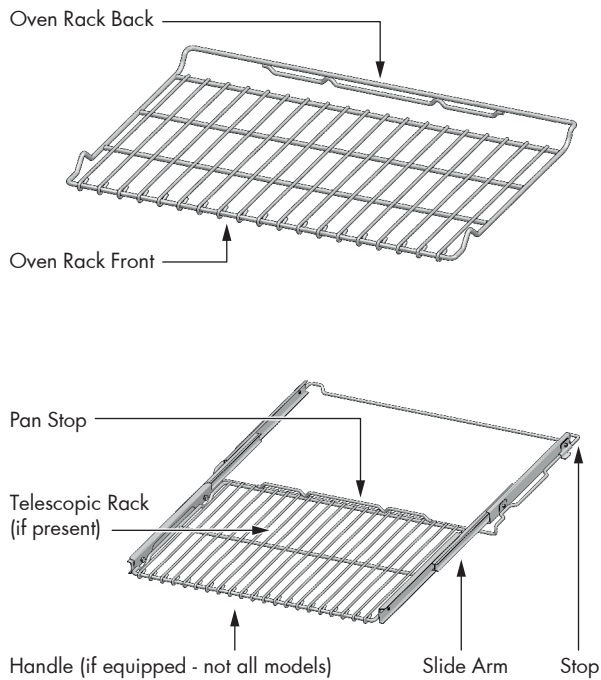
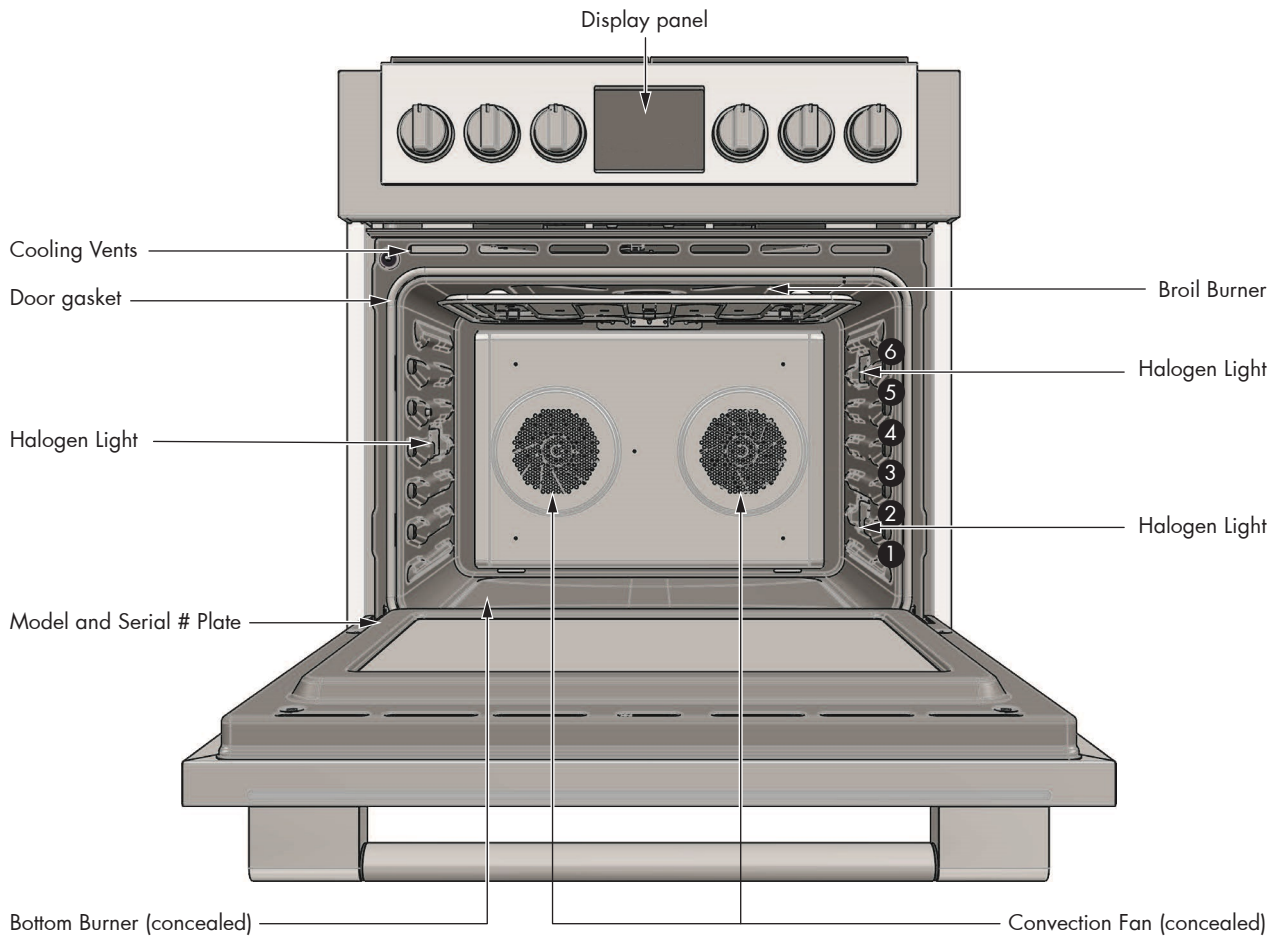
Your selection of a Sofia range confirms you are among a special group who share a love and passion for cooking. This unique community shares in the experience of creating quality dishes; dishes that will satisfy the palate while bringing the warmth of families and friends together to share and rejoice. Impress a loved one with your ability to combine flavours and ingredients or experiment with new foods and different culinary techniques to create unexpected pleasures.

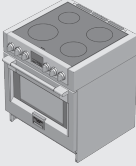

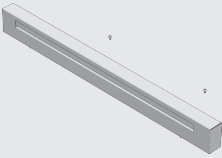
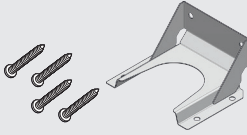
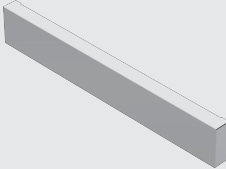
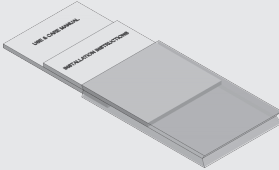

Gianni Alessandri

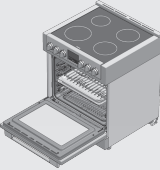
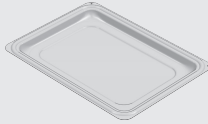
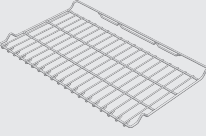

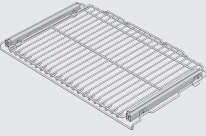

TABLE OF CONTENTS	PAGE
1 - Features of your Oven	2
2 - Special Warnings	4
Before Starting Installation	4
3 - Safety Instructions	5
Safety for the Oven	7
Safety for the Cooktop	7
Safety for the Self-Cleaning Oven	7
Warnings for Electric Installation	7
4 - Product Dimensions and Cutout Requirements	8
Anti-Tip Bracket Installation	10
5 - Installation Information	11
6 - Installation Instructions	12
7 - Electrical supply	15
Electricals	15
Connection to the electrical power mains	15
8 - Control Panel	17
Command Keys	18
Display	18
Knobs	18
9 - General Oven Information	18
10 - General Oven Tips	19
11 - Instruction for Use	20
Oven Racks	20
Oven Telescopic Racks	21
12- User Settings	22
13 - System Setting	23
14 - Starting your Oven	26
15 - Timed Oven Mode Operation	29
Cook time	29
Stop Time	29
16 - Setting the Meat Probe (if Present)	30
17 - Understanding the Various Oven Modes	32
18 - Recipes	32
19 - Classic Pizza (on some models)	37
20 - Sabbath Mode Instructions (on some models)	39
21 - Oven Care and Cleaning	40
22 - Setting The Self Cleaning Mode	41
23 - Do-it-Yourself Maintenance Oven Door Removal	42
To Remove Door	42
To Replace Door	42
29 - Replacing an Oven Light	43
To Replace a Light Bulb	43

TABLE OF CONTENTS	PAGE
25 - Features of your Cooktop	44
26 - Element and Control Setting	46
Control knobs and power level adjusting	46
Timer function setting	46
27 - Advice on cooking	48
28 - Induction Cooktop Operation	49
Before using the cooktop for the first time	49
29 - Cookware	51
How INDUCTION heating works	51
Pots and pans and how to use them	51
30 - General Oven Care	53
31 - Oven Finishes / Cleaning Methods	54
32 - Cleaning the Cooktop	55
33 - Solving Operational Problems	56
34- Resolution of operational problems COOKTOP	57
35 - Solving Baking Problems	58
36 - Assistance or Service	59

FEATURES OF YOUR OVEN



CONTENTS OF YOUR RANGE PACK					
	QTY	DESCRIPTION		QTY	DESCRIPTION
	1	RANGE COOKER		1	FOOT WITH COLLAR
	1	3" BACKSPLASH THREE FIXING SCREWS		1	ANTI TIP FOUR FIXING SCREWS
	1	KICK COVER			MANUAL & GENERAL DOCUMENTATION
	3	FEET		1	"INSTRUCTION MANUAL"
				1	"USE & CARE"

OVEN ACCESSORIES OF YOUR RANGE					
	QTY	DESCRIPTION		QTY	DESCRIPTION
	1	OVEN		1	ENAMELED ROASTING PAN
	2	CHROMED RACKS		1	ENAMELED ROASTING PAN GRATE
	1	TELESCOPIC CHROMED RACK		1	MEAT PROBE

IMPORTANT: Save these instructions for the local electrical inspector use.

INSTALLER: Please leave this manual with owner for future reference.

OWNER: Please keep this manual for future reference.

Pay attention to these symbols present in this manual:

 **DANGER**

You can be killed or seriously injured if you don't IMMEDIATELY follow instructions.

 **WARNING**

This is the safety alert symbol. This symbol alerts you to potential hazards that can kill or hurt you and others. You can be killed or seriously injured if you don't follow these instructions.

READ AND SAVE THESE INSTRUCTIONS.

To installer:

Leave these instructions with the appliance.

To customer:

Retain these instructions for future reference.



IMPORTANT INSTRUCTION

Please read all instructions before using this appliance.



Proper installation is your responsibility. Have a qualified technician install this range.

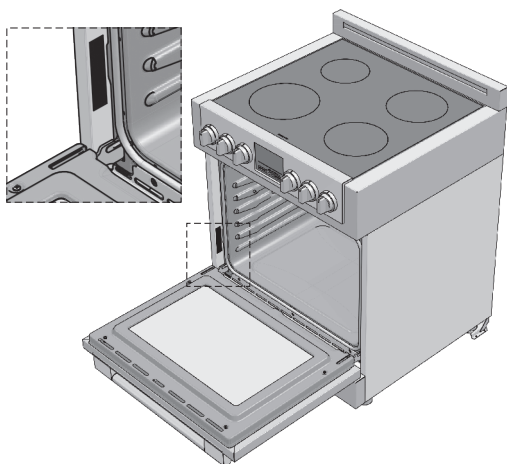
 **IMPORTANT**

- Observe all governing codes and ordinances.
- Write down the model and serial numbers before installing the range. Both numbers are on the serial rating plate refer to the illustration below.

Before Starting Installation

- Check location where range will be installed. The location should be away from strong drafty areas, such as windows, doors and strong heating vents or fans.
- Electrical grounding is required. See "Electrical Requirements"

LOCATION OF RATING PLATE



**IMPORTANT**

The appliance must be connected by qualified technician in accordance with the applicable regulations. The data plate of the oven is still visible after the appliance has been installed. This plate, which is visible when the oven door is open, contains all the identification data of the appliance.

Follow the instructions and suggestions carefully to ensure the safe and proper use of this product.

**IMPORTANT**

THIS APPLIANCE IS CONCEIVED FOR DOMESTIC USE ONLY. THE MANUFACTURER SHALL NOT IN ANY WAY BE HELD RESPONSIBLE FOR WHATEVER INJURIES OR DAMAGES ARE CAUSED BY INCORRECT INSTALLATION OR BY UNSUITABLE, WRONG OR ABSURD USE.

**IMPORTANT**

THIS APPLIANCE IS NOT INTENDED FOR USE BY PERSONS (INCLUDING CHILDREN) WITH REDUCED PHYSICAL, SENSORY OR MENTAL CAPABILITIES, OR LACK OF EXPERIENCE AND KNOWLEDGE, UNLESS THEY HAVE BEEN GIVEN SUPERVISION OR INSTRUCTION CONCERNING USE OF THE APPLIANCE BY A PERSON RESPONSIBLE FOR THEIR SAFETY.

CHILDREN SHOULD BE SUPERVISED TO ENSURE THAT THEY DO NOT PLAY WITH THE APPLIANCE.

- Do not disassemble any parts prior to having disconnected the Range from the mains.
- Do not use the appliance if any part is broken (for example a glass). Disconnect it from the mains and call service.
- Before using the oven, it is recommended to make it operate at no-load at the maximum temperature for an hour to eliminate the insulating material odour.
- In all models, leave the door closed when the grill is used.
- The cooling fan may remain in operation so long as the oven is hot, even after it has been switched off.
- During the use the appliance becomes very hot; don't touch the heating elements inside the oven.
- During the oven operation, the front is heated as well; consequently keep children clear of the oven, especially during self-cleaning.
- Parents and adults should pay particular attention when using the product in presence of children.
- Children should be overseen so as to ensure that they don't play with the equipment.
- **Keep children under age 8 away, unless constantly supervised.**
- This appliance is not intended for use by persons (including children over age 8) with reduced physical sensory or mental capabilities, or lack of experience and knowledge, unless they have been given supervision or instruction concerning use of the appliance by a person responsible for their safety.
- **Children may not perform cleaning and maintenance unsupervised.**

- In order to avoid damage to the oven enamel coat, do not cover the oven muffle sole with any item (e.g. aluminum foil, pans and the likes).
- Do not use harsh abrasive cleaners or sharp metal scrapers to clean the oven door glass since they can scratch the surface, which may result in shattering of the glass.
- Abrasive detergents and steam cleaning equipment should not be used for cleaning.
- Before performing self-cleaning, take out all accessories (grills, dishes, pans) to avoid damaging them, remove large cooking residues and then close the door, ensuring that it is closed properly.
- The oven is cool and power to the oven has been turned off before removing the door. Failure to do so could result in electrical shock or burns.
- The appliance must not be installed behind a decorative door in order to avoid overheating.

 **WARNING**

Ensure that the appliance is switched off before replacing the lamp to avoid the possibility of electric shock.

- Use only the meat probe supplied with the appliance.
- Prolonged intensive use of the appliance may call for additional ventilation, for example opening of a window, or more effective ventilation increasing the level of mechanical ventilation where present.
- Do not use cooking vessels or pans on the hotplate that overlap its edges.

To reduce the risk of burn injuries during cooktop use, observe the following:

- Children or pets should not be left alone or unattended in an area where appliances are in use.
- Children should never be allowed to sit or stand on any part of the appliance.
- Do not store flammable materials on or near the cooktop.
- Use only dry potholders; moist or damp potholders on hot surfaces may cause burns from steam.
- Never leave the cooktop unattended when in use.
- Always position handles of utensils inward so they do not extend over adjacent work areas, burners, or the edge of the cooktop.
- Wear proper apparel. Loose fitting garments or hanging sleeves should never be worn while cooking.
- Do not clean the cooktop while it is still hot. Some cleaners produce noxious fumes when applied to a hot surface.

 **CAUTION**

Do not allow pans to boil dry.

 **CAUTION**

Do not store items of interest to children above the appliance. If children should climb onto the appliance to reach these items, they could be seriously injured.

To reduce the risk of fire in the oven cavity:

1. Do not store flammable materials in or near the oven.
2. Do not use water on a grease fire. Smother fire or use a dry chemical or foam-type extinguisher.
3. It is highly recommended that a fire extinguisher be readily available and highly visible next to any cooking appliance.
4. Do not overcook food. Carefully attend oven if paper, plastic or other combustible materials are placed inside the oven.
5. Do not use the cavity for storage purposes. Do not leave paper products, cooking utensils or food in the cavity when not being used.
6. If materials inside the oven should ignite, keep oven door closed. Turn oven off and disconnect the circuit at the circuit breaker box.
7. Do not block any vent openings.
8. Be sure the blower fan runs whenever the oven is in operation. If the fan does not operate, do not use the oven. Call an authorized service center.
9. For personal safety, wear proper clothing. Loose fitting or garments with hanging sleeves should never be worn while using this appliance.

Safety for the Oven

- Tie long hair so that it doesn't hang loose.
- Do not touch heating elements or interior surfaces of oven.
- The heating elements may be hot even though they are dark in color. Interior surfaces of an oven become hot enough to cause burns.
- During and after use, do not touch or let clothing or other flammable materials contact the heating elements or the interior surfaces of the oven until they have had sufficient time to cool. Other surfaces of the appliance may become hot enough to cause burns for example, oven vent openings and surfaces near these openings, oven doors, and windows of oven doors.
- The trim on the top and sides of the oven door may become hot enough to cause burns.
- Use care when opening the door. Open the door slightly to let hot air or steam escape before removing or replacing food.
- Do not heat unopened food containers. Build-up of pressure may cause the container to burst and cause injury.
- Always place oven racks in desired location while oven is cool. If a rack must be moved while oven is hot, do not let pot holder contact the hot heating elements.
- Use only dry pot holders. Moist or damp pot holders on hot surfaces may result in burns from steam. Do not let pot holder touch hot heating elements. Do not use a towel or other bulky cloth.

Safety for the Cooktop

Use Proper Pan Size

- This appliance is equipped with one or more surface units of different size. Select utensils having flat bottoms large enough to cover the surface unit heating element. The use of undersized utensils will expose a portion of the heating element to direct contact and may result in ignition of clothing. Proper relationship of utensil to burner will also improve efficiency.

Utensil Handles Should Be Turned Inward and Not Extend Over Adjacent Surface Units

- To reduce the risk of burns, ignition of flammable materials, and spillage due to unintentional contact with the utensil, the handle of a utensil should be positioned so that it is turned inward, and does not extend over adjacent surface units.

Do Not Cook on Broken Cook-Top

- If cook-top should break, cleaning solutions and spillovers may penetrate the broken cooktop and create a risk of electric shock. Contact a qualified technician immediately.

Clean Cook-Top With Caution

- If a wet sponge or cloth is used to wipe spills on a hot cooking area, be careful to avoid steam burn. Some cleaners can produce noxious fumes if applied to a hot surface.

Safety for the Self-Cleaning Oven

- Make sure that the door is locked and that it cannot be opened once the knob is turned into the CLEAN position and once the icon of the locked door appears. If the door does not lock, turn the cook mode selector to OFF and do not run Self-Clean. Contact Service.
- Do not clean the door gasket. It is essential for a good seal. Care should be taken not to rub, damage, move or remove the door gasket.
- Do not use commercial oven cleaners or oven liner protective coatings of any kind in or around any part of the oven.
- Clean only oven parts listed in this manual.
- Before self-cleaning the oven, remove the broiler pan, oven racks (only when not made of porcelain), other utensils and excess soft spillage.



WARNING

The elimination of soil during self-cleaning generates some by-products which are on this list of substances. To minimize exposure to these substances, always operate this oven according to the instructions in this manual and provide good ventilation to the room during and immediately after self-cleaning the oven.

Warnings for Electric Installation



WARNING

Installation and service must be performed by a qualified installer, service agency.

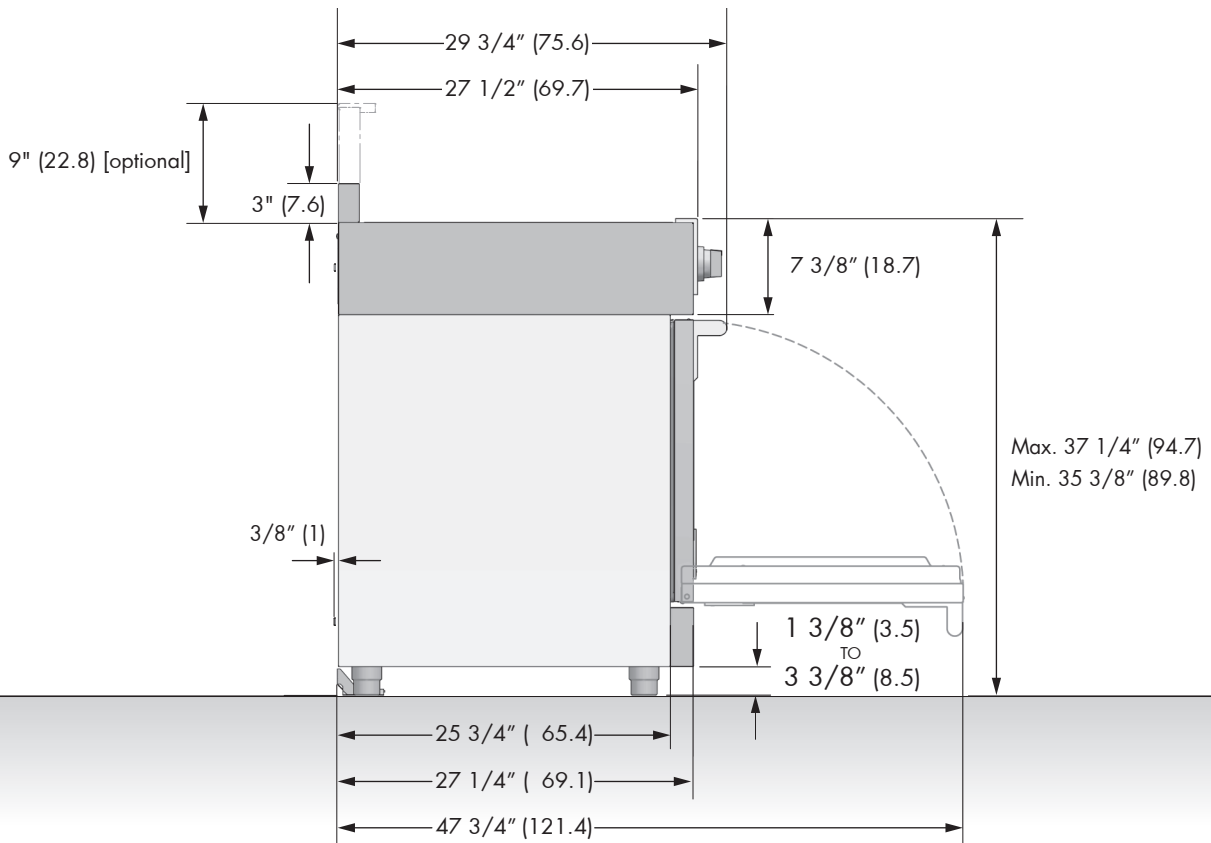
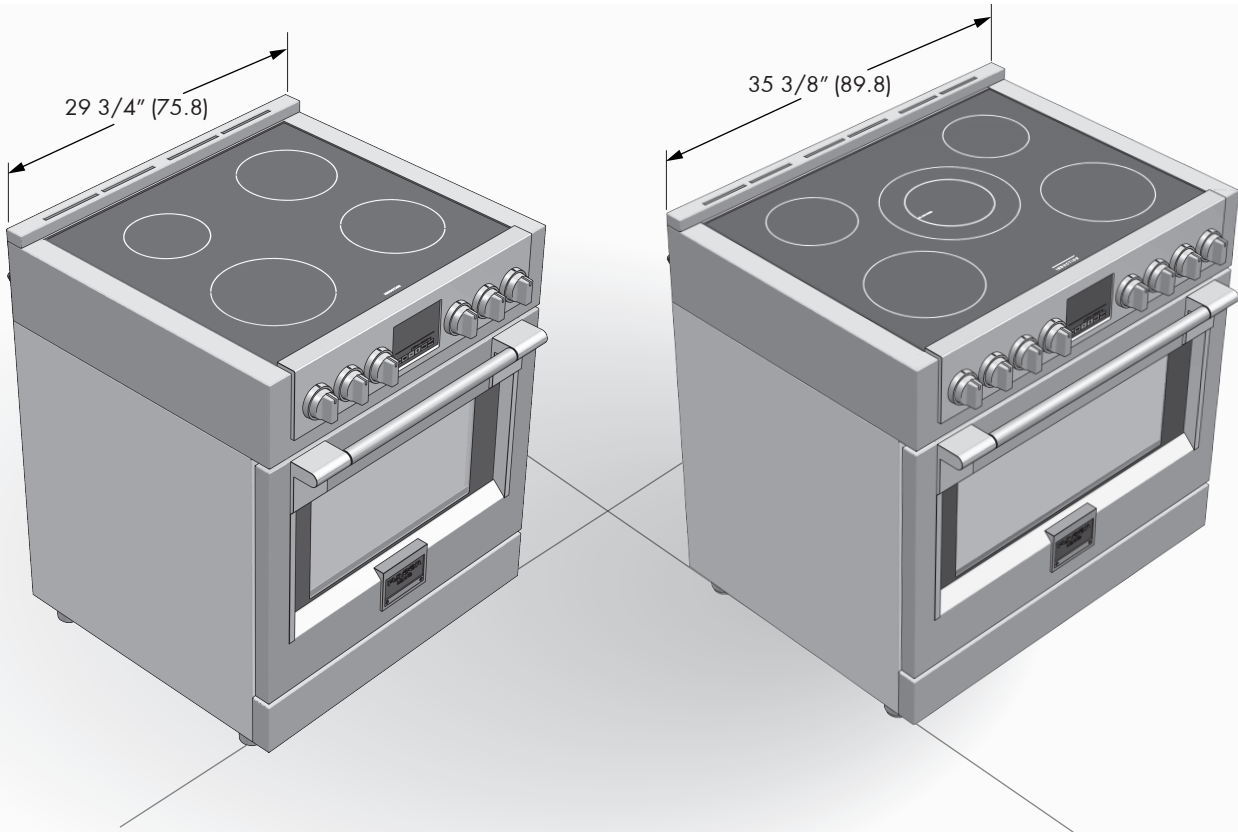


CAUTION

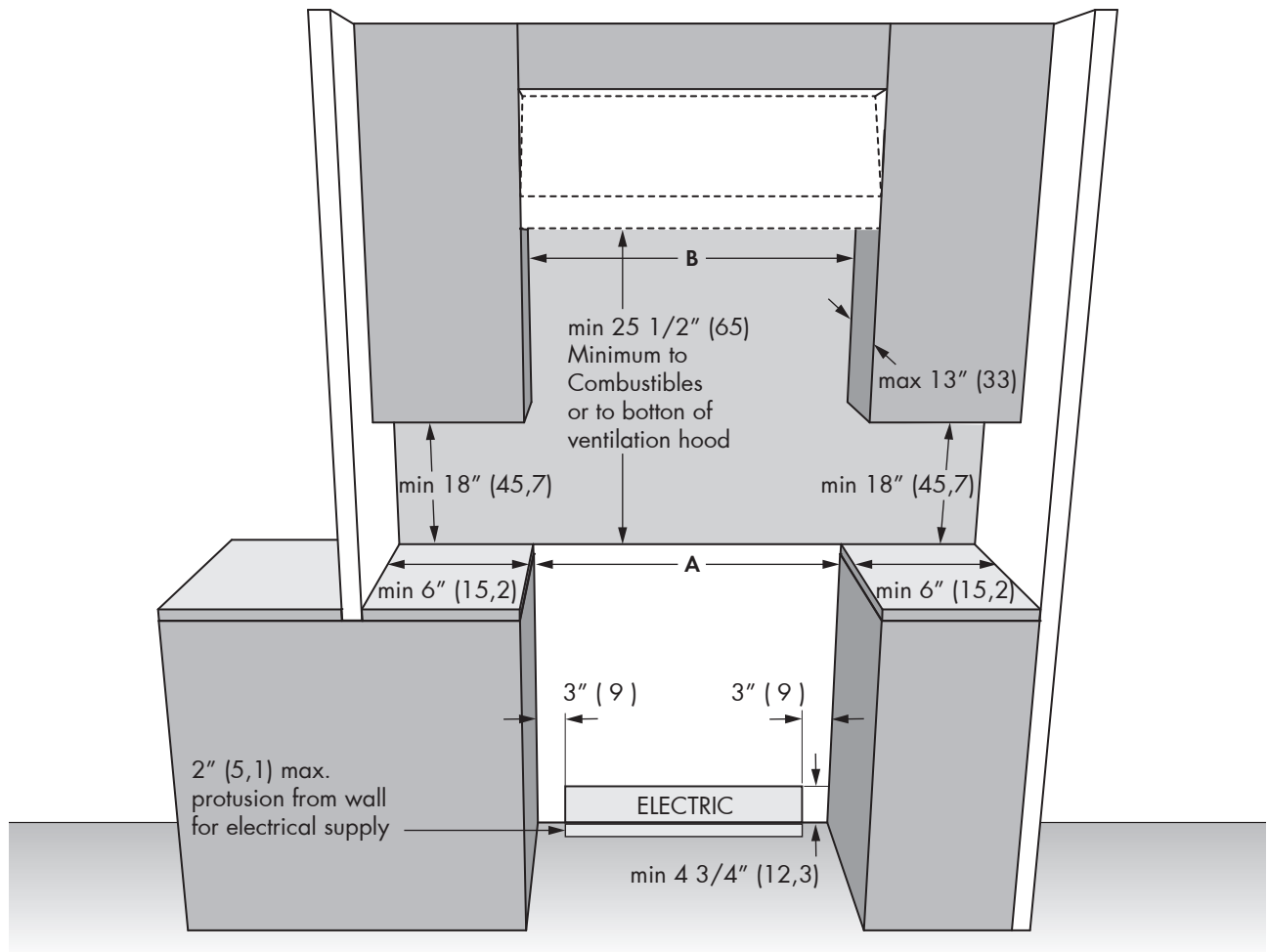
- Always disconnect the electrical plug from the wall receptacle before servicing this unit.
- For personal safety, this appliance must be properly grounded.
- Do not under any circumstances cut or remove the third (ground) prong from the power cord plug.

PRODUCT DIMENSIONS

76,2 cm (30'') and 91,4 cm (36'') Wide Range Models



CUTOUT REQUIREMENTS



The surface of the entire back wall above the range and below the hood must be covered with a noncombustible material.

*Consult local code for exact location requirements.

OPENING WIDTH	A & B
Range 76.2 cm (30")	76.2 cm (30")
Range 90.1 cm (35 1/2")	90.1 cm (35 1/2")

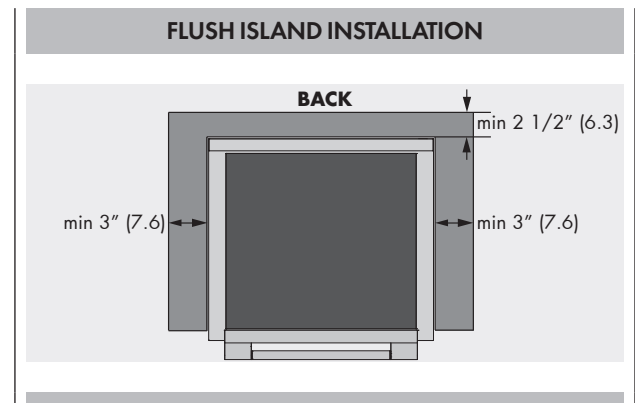
ADDITIONAL CLEARANCES:

For island installation, maintain 2-1/2 in. minimum from cutout to back edge of countertop and 3 in. minimum from cutout to side edges of countertop (see top view).

Minimum clearances:

Above cooking surface (above 36" [91.4 cm])

- Sides - 3" (7.6 cm)
- Within 3" (7.6 cm) side clearance, wall cabinets no deeper than 13" (33.0 cm) must be minimum 18" (45.7 cm) above cooking surface
- Rear - 0" with 3" (7.6 cm) backguard.



Before moving the range, protect any finished flooring and secure oven door(s) closed to prevent damage.

Vent hood Combinations:

It is recommended that these ranges be installed in conjunction with a suitable overhead vent hood.

Due to the high heat capacity of this unit, particular attention should be paid to the hood and ductwork installation to assure it meets local building codes.

WARNING

Clearances to horizontal surfaces above the range, measured to the cooking surface are below. Failure to comply may result in fire hazard.

- A custom hood installation with exposed horizontal combustible surfaces must have an Auto-On feature.
- For other installations with a hood, refer to the hood installation instructions for specific hood clearances.

CAUTION

These ranges weigh up to 400 pounds (180Kg). Some disassembly will reduce the weight considerably. Due to the weight and size of the range and to reduce the risk of personal injury or damage to the product:

TWO PEOPLE ARE REQUIRED FOR PROPER INSTALLATION.

Anti-Tip Bracket Installation

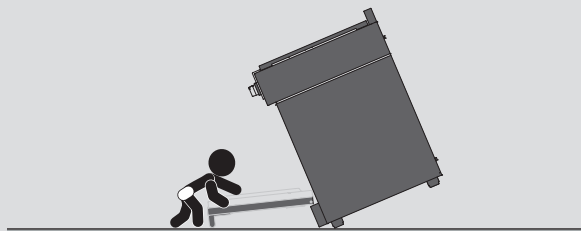
WARNING

Tip Over Hazard

A child or adult can tip the range and be killed. Ensure the anti-tip bracket is engaged when the range is moved.

Do not operate range without anti-tip bracket installed and engaged.

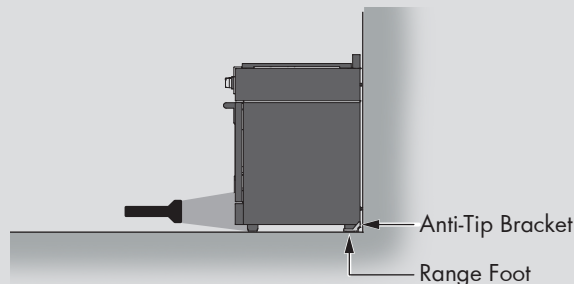
Failure to follow these instructions can result in death or serious burns to children and adults.



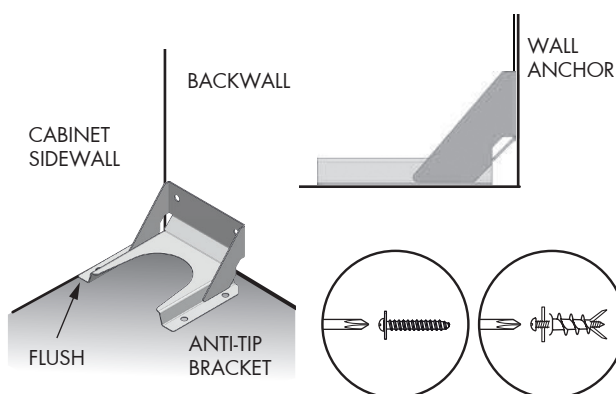
WARNING

To verify the anti-tip bracket is installed and engaged:

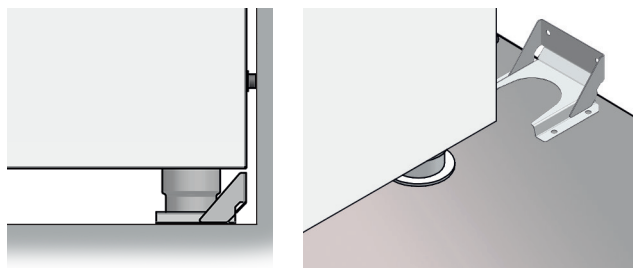
- Slide range forward.
- Look for the anti-tip bracket securely attached to floor or wall.
- Slide range back so rear range foot is under anti-tip bracket.
- See installation instructions for details.



ANTI-TIP BRACKET INSTALLATION



For Concrete or Cement Construction:
You must use appropriate fastening hardware (not provided).
Secure the bracket to the wall and/or floor with at least 4 wood screws (provided).



The anti-tip bracket should be inserted into the opening on the anti-tip brace on the range.

⚠ WARNING

• **Excessive Weight Hazard**

Use two or more people to move and install range. Failure to do so can result in back or other injury.

• **Cut Hazard**

Beware of sharp edges. Use the polystyrene ends when carrying the product. Failure to use caution could result in minor injury or cuts.

Do not obstruct the flow of combustion air at the oven vent nor around the base or beneath the lower front panel of the range. Avoid touching the vent openings or nearby surfaces as they may become hot while the oven is in operation.

CHOOSING RANGE LOCATION

Carefully select the location where the range will be placed. The range should be located for convenient use in the kitchen, but away from strong drafts. Strong drafts may be caused by open doors or windows, or by heating and/or air conditioning vents or fans.

⚠ IMPORTANT NOTE

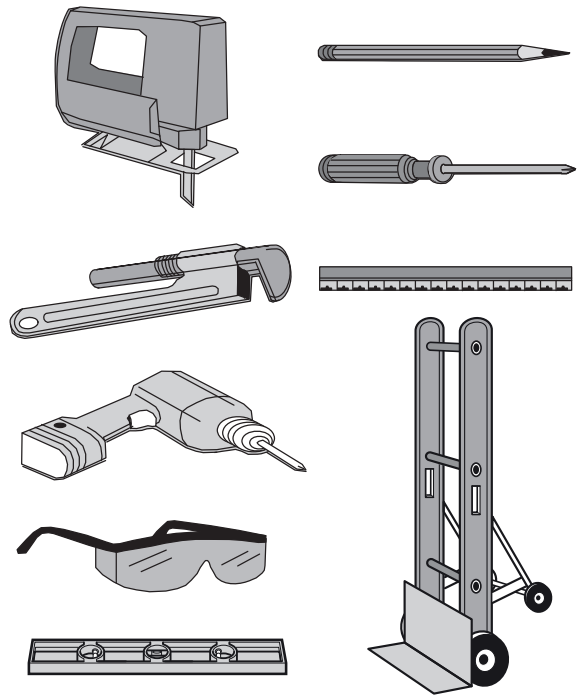
When installing against a combustible surface, a minimum riser is required for a the range, Follow all minimum clearances to combustible surfaces shown in the illustration on the previous pages.

Before moving the range, protect any finished flooring and secure oven door(s) closed to prevent damage.

Do not lift or carry the range door by the door handle.

To eliminate the risk of burns or fire by reaching over heated surface units, cabinet storage space located above the surface units should be avoided. If cabinet storage is to be provided, the risk can be reduced by installing a range hood that projects horizontally a minimum of 12 inches beyond the bottom of the cabinets.

TOOLS WILL YOU NEED



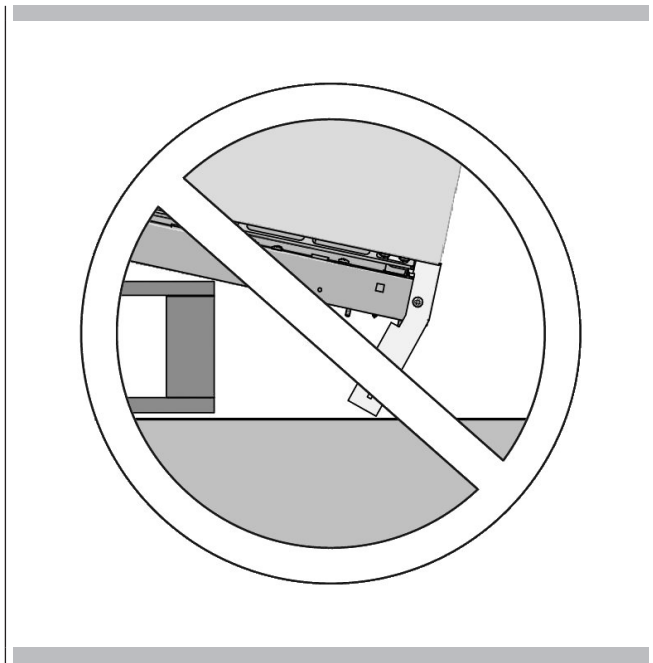
Remove packaging materials and literature package from the cooktop before beginning installation. Remove Installation Instructions from the literature pack and read them carefully before you begin.

MATERIALS PROVIDED



Anti-tip bracket
brace and screws

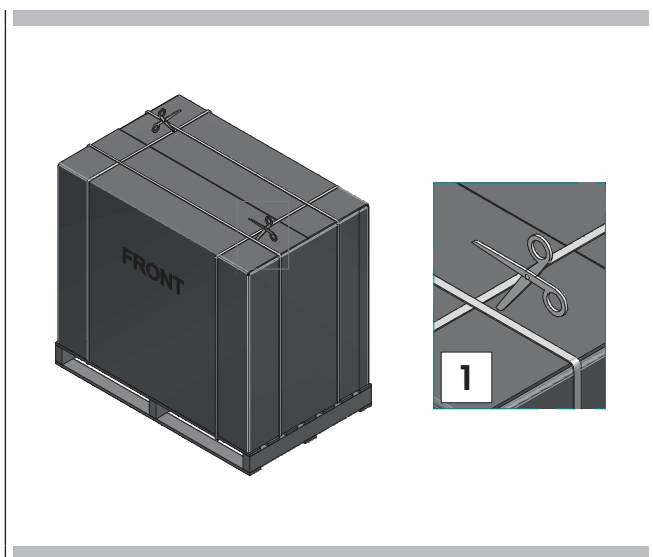
Do not tip the range on its side when installing the legs. The sidewalls are not designed to bear the weight of the range and will bend. Any damage as a result of tipping will not be covered by warranty. Follow the method in the enclosed installation Manual.



STEP 1

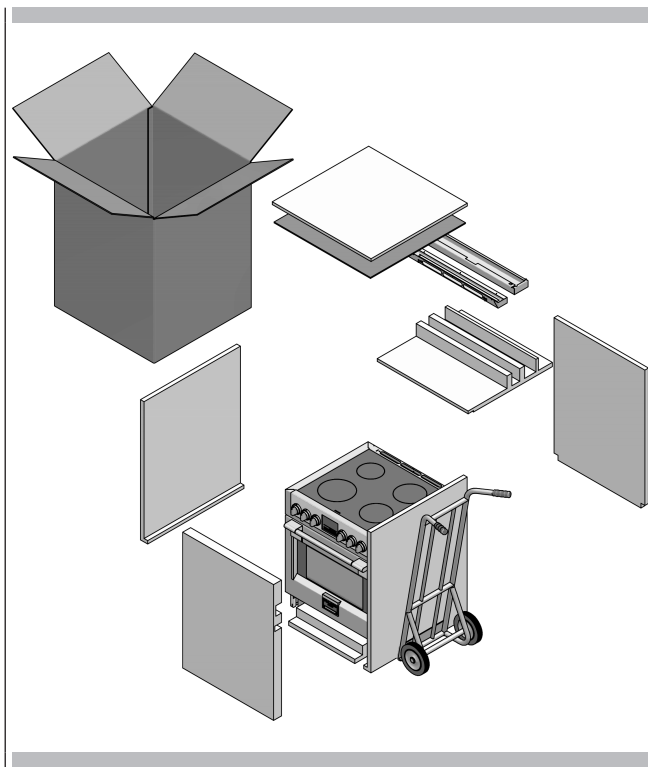
Cut the banding (1) and remove the Installation Instructions from the top of range and read them carefully before you begin.

 **CAUTION**
Stand clear. The ends of the cut banding may snap toward you.



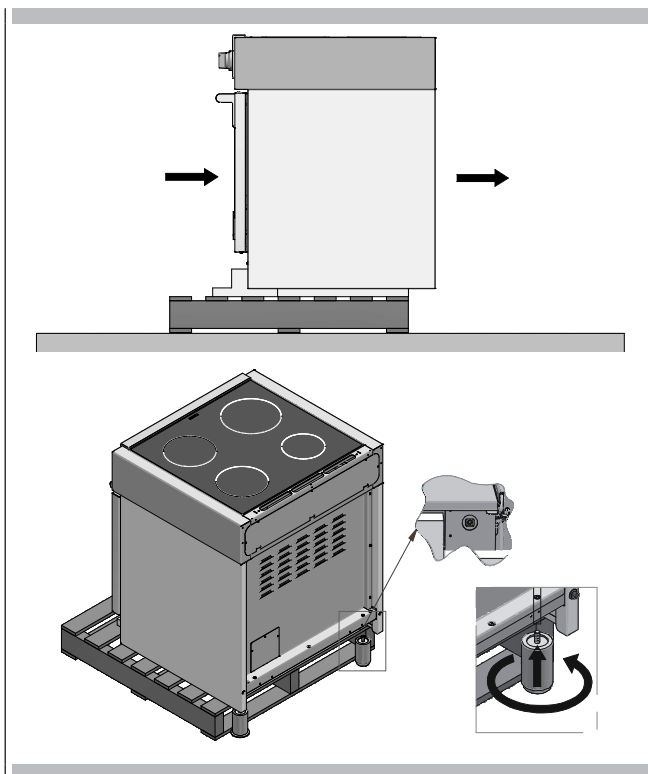
STEP 2

Open the top and remove the accessories then lift off the cardboard sheath.



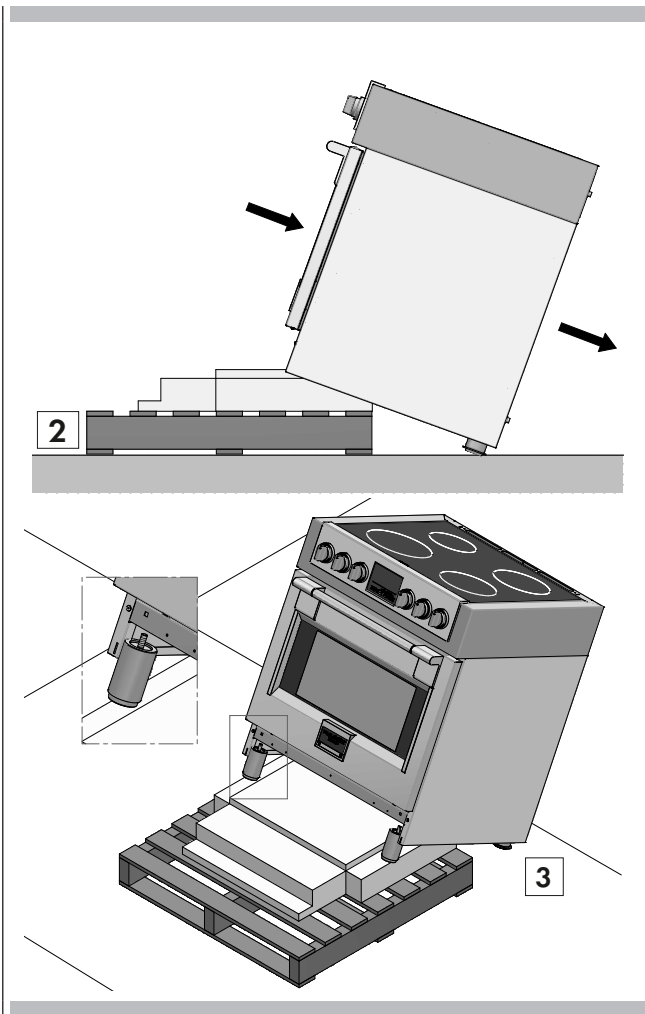
STEP 3

Slide the range back just enough to allow the rear feet to be installed.



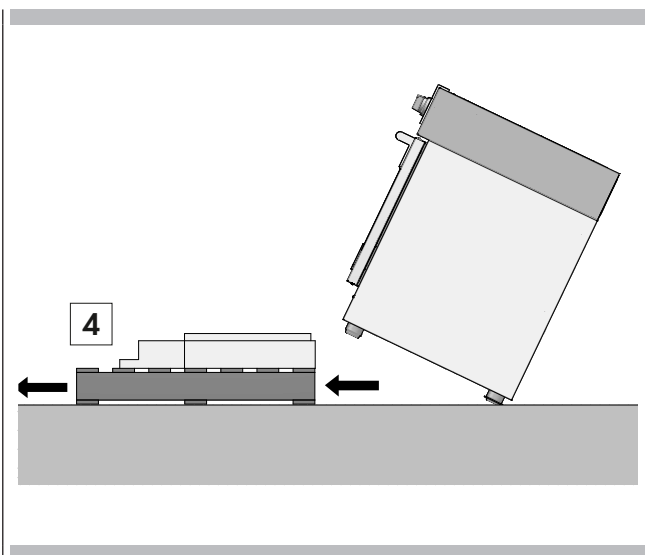
STEP 4

Slide back more and tilt back (2), putting the rear legs on the floor and then mount the front legs (3) while in this angled position supported by the rear legs and the skid.



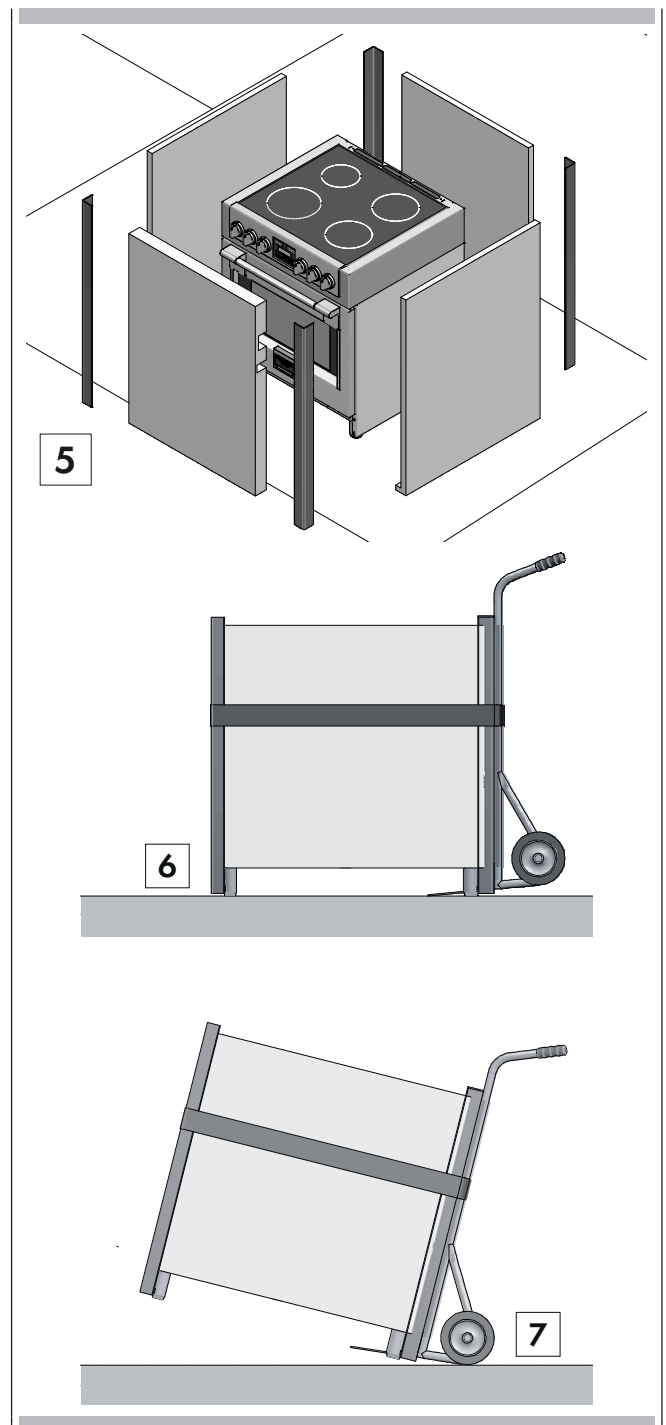
STEP 5

Remove the base while supporting the front of the range (4) and lower to the floor in a controlled manner.



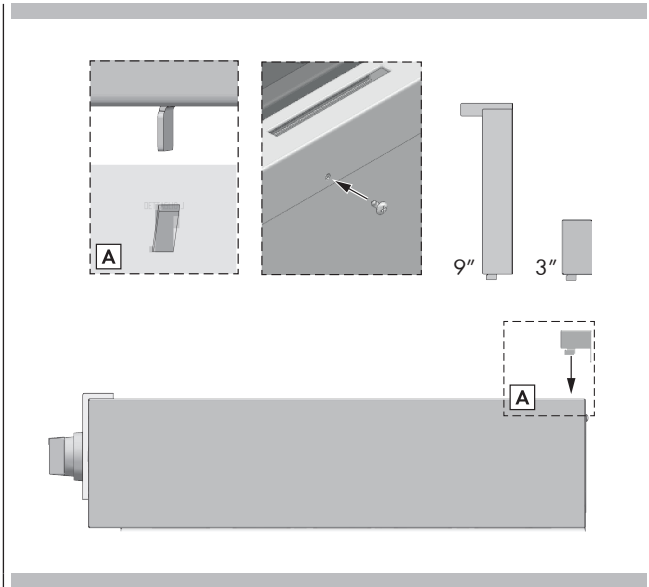
STEP 6

In case it is necessary to move the range; using the foam and/or cardboard packaging (5), replace them around the range strategically to protect the finished surfaces of the range from contact with the hand-truck and any straps around the unit (6). In the case of smaller ranges, you may use this technique to remove the range from the skid and installing the legs (7). Tilt the range to lower the hand-truck wheels off the skid. Place appliance runners on the floor at the left and right sides in front of the opening when moving into final position to protect flooring. The oven door(s) add(s) a great deal to the overall weight of the range, you may find it helpful to remove the doors if moving the range a significant distance. Refer to the included instruction manuals for how to remove and reinstall the doors.



STEP 7

Install the back guard (if provided) by the three screws on the back. In some cases this may be an accessory back guard that was ordered separately rather than the one which was included with the range. Refer to instructions included with any accessory for specific installation requirements.



STEP 8

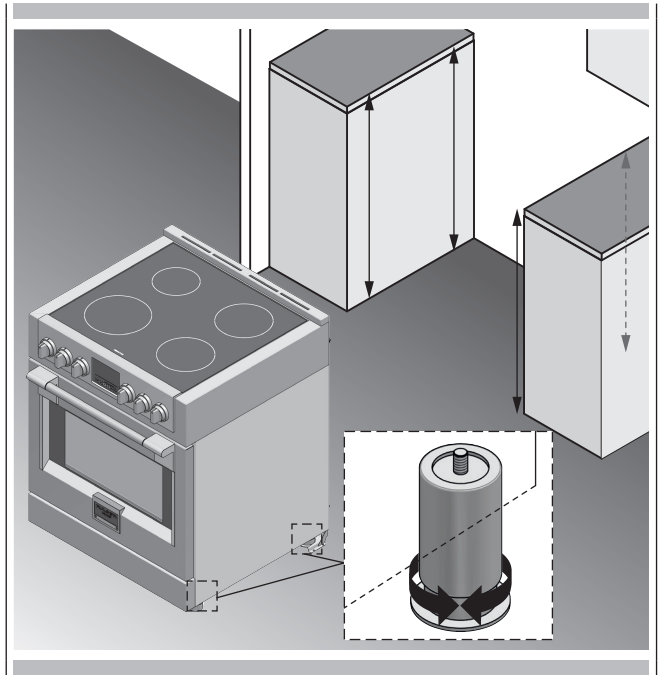
After completing the electrical connection (see included instructions) measure the four corners in cutout area to verify if flooring is level. Adjust the leveling legs to the desired height and ensure range is level. Turn the bottom section of each leg counter-clockwise to raise the leg and clockwise to lower it.



IMPORTANT

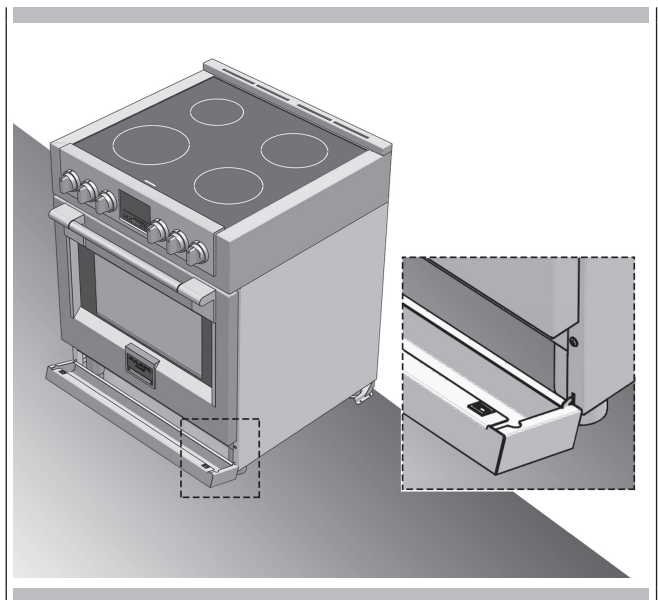
When the unit first powers on, it must complete a safety door lock test. Ensure doors are reinstalled if they were removed to ease movement of the range prior to sending power to the appliance. Do not open the oven door or attempt to use the oven until you are sure the test has been completed successfully. Opening / closing the door during the test could result in damage to the lock mechanism. Refer to the instruction manuals for more details if needed.

Ensure floor is protected. Slide unit into place making sure to engage the anti-tip bracket.



STEP 9

Hook tabs on bottom of toekick into slots on either side of the frame and rotate up until the magnets at the top of toekick make contact and hold it in place securely



Electricals

ABSORBED POWER	
oven top element:	3500 + 1000W 230V - 3500 + 1000W 240V
oven bottom element:	3000W 230V - 3000W 240V
round element (hot air):	2x1300W 240V or 1x2500W 240V (depending on model)
lamp:	3x25W
hot air fan motor:	2x44W or 1x44W (depending on model)
cooling fan motor:	44W
induction modules:	3600W x 2 (30") or 3600W x 3 (36")
MAXIMUM ABSORBED POWER: (see data plate)	
SUPPLY VOLTAGE: (see data plate)	

Connection to the electrical power mains

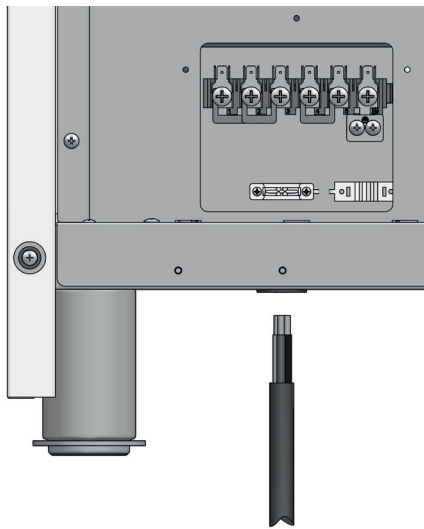
⚠ WARNING
This apparatus must be earthed.

The appliance is only for domestic use. The feed voltage and the absorbed power are as indicated on the data plate attached to the left-hand side upright, which can be seen when the oven door is open. Connecting must be carried out by qualified personnel and in accordance with the regulations currently in force. The manufacturer can not be held responsible for any damages to persons or objects caused by failure to observe these instructions. If the supply cord is damaged, it must be replaced by the manufacturer, its service agent or similarly qualified persons in order to avoid a hazard. The appliance must be connected to the mains through a multipole circuit breaker with a contact-to-contact gap of at least 3 mm, making sure that the earth wire is not disconnected. For connecting use a flexible cable remembering to make it long enough to allow the appliance to be removed from its housing unit when maintenance work is required. The terminal box is located at the rear of the appliance. If a new cable is fitted, route it through the clamp and make the connections as shown in the diagram. The earth wire must be cut longer than the other wires so that it will be the last to break off in the event of the cable being tugged. Having made the connection, tighten the cable clamp and close the cover of the box.

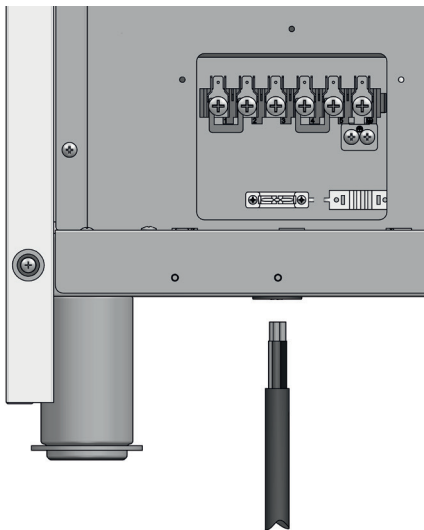
CABLE TYPES
H05RR-F
H05SS-F
H05VV-F
H05RN-F
H05V2V2-F
FG7OR

Figure	Diagram	Cable
A (30") 75cm	<p>220-240V~ or 240V~</p>	3x10 mm
B (30") 75cm	<p>220-240V 3~ or 240V 3~</p>	4x6 mm
B (30") 75cm	<p>380-415V 2N~ or 415V 2N~</p>	4x6 mm
C (30") 75cm (36") 90cm	<p>380-415V 3N~ or 415V 3N~</p>	5x2,5 mm

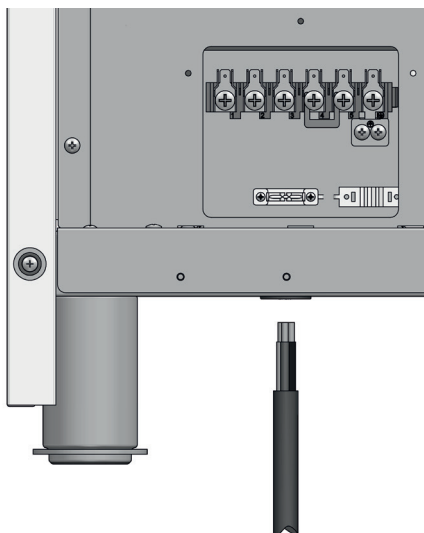
CONNECTION A



CONNECTION B

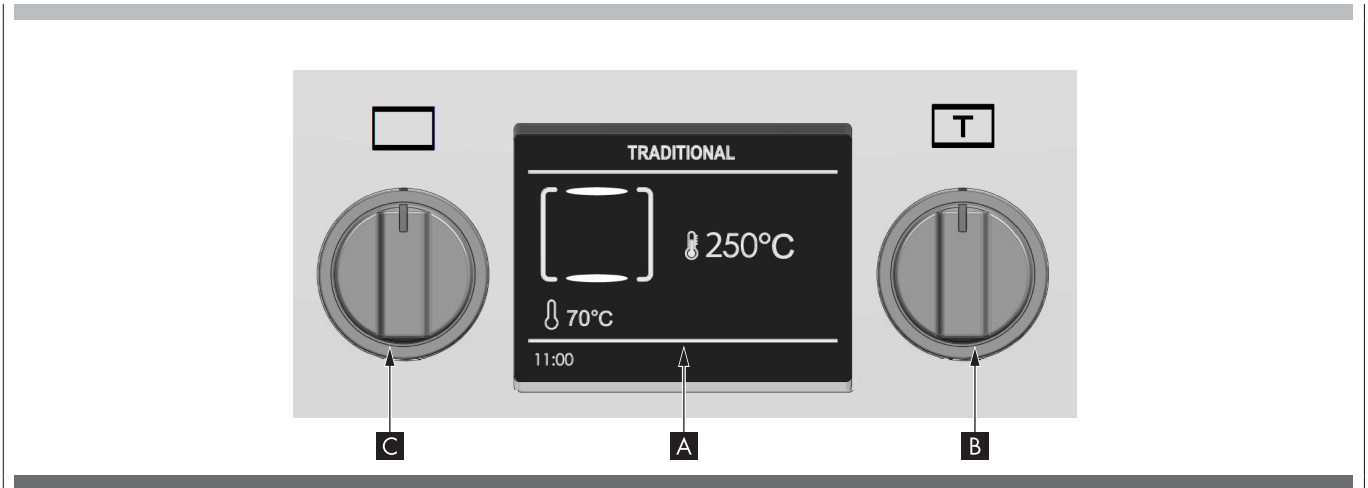


CONNECTION C



Your appliance could vary slightly compared to the illustrations below.

- A** - Display screen
- B** - Temperature Knob
- C** - Function Knob



Command Knobs

To operate the control knobs, rotate them to left/right press gently. The control will not work if more than one knobs is pressed or rotate at the same time.

ON/OFF & TEMP KNOB



PRESS ON/OFF: Switches the oven ON and OFF.

ROTATE ◀ + : Increase Temperature Setting

ROTATE ▶ - : Decrease Temperature Setting

FUNCTION KNOB



PRESS OK: Confirm the setting and starts cooking operations.

PRESS LIGHT: Switches the oven light ON/OFF only when pressed during a cooking operation.

ROTATE LEFT ◀ : Rotate to move the display selection.

ROTATE RIGHT ▶ : Rotate to move the display selection.

ROTATE BACK (2 sec.): Return to previous display page.

ROTATE LOCK (2 sec.): Activation of key and Door lock.

Before using your oven for the first time remove all packing and foreign materials from the oven(s). Any material of this sort left inside may melt or burn when the appliance is used.

Error codes

This code appears in the event of the electronic control indicating a fault. When the error appears, the current function is blocked. If the type of error is related to a safety function, the oven becomes unusable and every time a start attempt is made, the same error appears (in which case call in the after-sales service), while if the error relates to a minor fault, after being restarted the oven can be used for the functions that do not involve the faulty part (e.g., a heating element).

Beeps

Confirm that the command has been received after a knob has been pressed.

It also indicates that a time function has been completed (e.g. Timer or Timed Cooking). During the execution of a recipe, an acoustic signal warns the user that the oven is waiting for operation by the user (e.g., insert the dish or turn it over).

Beeps also signal an oven fault.

Door Lock

It's displayed steadily when the door is locked. The symbol flashes when the latch is moving in order to lock or unlock the door. Do not attempt to open the door at this time. Door can be opened when the symbol no longer appears. A padlock appears when the door has been locked automatically due to self-clean mode.

Power Failure

After the power returns to the oven, the door lock mechanism perform a test run then the clock time and date are displayed.

Default Settings

The cooking modes automatically select a suitable temperature when the cooking mode is selected, these can be changed when a different one is needed.

F Failure Number Codes



These codes are displayed when the electronic control detects a problem in the oven or in the electronics.

The error code is recorded in the Error Log in the Setup menu. This error can be communicated to the service technician so he/she can understand the possible cause of the problem in advance.

Preheat and Fast Preheat

Whenever a cooking mode is set and the oven is heating, the preheating starts, during this period, the instantaneous temperature is displayed together with the thermometer icon.

As soon as the 100% is reached, the control sounds an "end of preheat" tone and the current temperature value disappears.

When it's necessary to heat up the oven rapidly, a Fast Preheat mode is available: it uses the heating elements and the convection fan in a special way, in order to reduce the heating time as long as possible. After having set one of the cooking functions for which the fast preheat is available and set the desired temperature value, then turn the knob to the RIGHT, after entering the functions menu, select the icon  by means of the knob  and confirm by means of the pressing [FUNCTIONS] knob. As soon as the set-point temperature is reached, the control sounds a and both "Fast Preheat Icon" and "current temperature" disappear. The oven switches automatically to the desired cooking mode that was previously set: put the food inside now.


Timer



WARNING

The timer on your oven does not turn the appliance on or off, its only purpose is to alert you through the buzzer. When you want to turn off the oven automatically, use the end-of-cooking or delayed cooking function.

NOTE: Pressing the OFF knob does not reset or stop the timer.

1. Select the function  and set the desired time using the function knob and confirm by means of the pressing function knob.
2. The time can be set from 1 minute to 12 hours and 59 minutes and, when set, the remaining time is always visible in the bottom status bar until the time expires or is reset.
3. To cancel the time set, you must reset the timer by pressing the [FUNCTION] Knob for 2 seconds when you are in timer setting menu.
4. Timer format is usually HR:MIN, switching into MIN:SEC during the last minute.
5. When the time expires, the display shows 00:00 and the buzzer will sound for one minute or until the [FUNCTION] knob is pressed.

Preheating the Oven

- Preheat the oven when using the Bake, Convection Bake and Convection Roast modes.
- Use Fast Preheat mode when a shorter time is desired to preheat the oven.
- Selecting a higher temperature does not shorten the preheat time.
- Preheating is necessary for good results when baking cakes, cookies, pastry and breads.
- Preheating will help to sear roasts and seal in meat juices.
- Place oven racks in their proper position before preheating.
- During preheating, the selected cooking temperature is always displayed.
- A beep will confirm that the oven is preheated and the "detected temperature" will turn off.

Operational Suggestions

- Do not set pans on the open oven door.
- Use the interior oven lights to view the food through the oven door window rather than opening the door frequently.

Utensils

- Glass baking dishes absorb heat. Reduce oven temperature 25 F (15 C) when baking in glass.
- Use pans that give the desired browning. The type of finish on the pan will help determine the amount of browning that will occur.
- Shiny, smooth metal or light non-stick / anodized pans reflect heat, resulting in lighter, more delicate browning. Cakes and cookies require this type of utensil.
- Dark, rough or dull pans will absorb heat resulting in a browner, crisper crust. Use this type for pies.
- For brown, crisp crusts, use dark non-stick / anodized or dark, dull metal utensils or glass bake ware. Insulated baking pans may increase the length of cooking time.
- Do not cook with the empty broiler pan in the oven, as this could change cooking performance.
- Store the broil pan outside of the oven.

Oven Condensation and Temperature

- It is normal for a certain amount of moisture to evaporate from the food during any cooking process. The amount depends on the moisture content of the food. The moisture may condense on any surface cooler than the inside of the oven, such as the control panel.
- Your new oven has an electronic temperature sensor that allows maintaining an accurate temperature. Your previous oven may have had a mechanical thermostat that drifted gradually over time to a higher temperature. It is normal that you may need to adjust your favorite recipes when cooking in a new oven.

High Altitude Baking

- When cooking at high altitude, recipes and cooking time will vary from the standard.

The first time you use the oven

Clean the oven thoroughly with soapy water and rinse well. Operate the oven for about 30 minutes at maximum temperature to burn off all traces of grease which might otherwise create unpleasant smells when cooking.

WARNING

Never use aluminum foil to cover the oven racks or to line the oven. It can cause damage to the oven liner if heat is trapped under the foil.

WARNING

Make sure you do not force it to avoid damage to the enamel.

Oven Racks

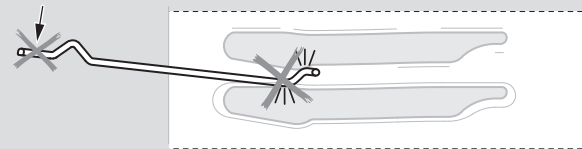
- The oven has rack guides at six levels as shown in the illustration on Page 2.
- Rack positions are numbered from the bottom rack guide (#1) to the top (#6).
- Check cooking charts for best rack positions to use when cooking.
- Each level guide consists of paired supports formed in the walls on each side of the oven cavity.
- Always be sure to position the oven racks before turning on the oven. Make sure that the racks are level once they are in position. Please refer to illustration on Page 2 if there is any question as to which side is the front of the rack.
- The racks are designed to stop when pulled forward to their limit.

CAUTION

Never use aluminum foil to cover the oven racks or to line the oven. It can cause damage to the oven liner if heat is trapped under the foil.

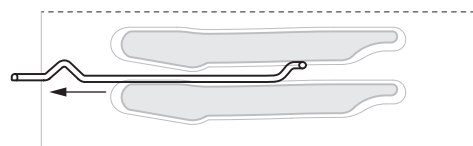
CAUTION

Make sure you do not force it to avoid damage to the enamel.

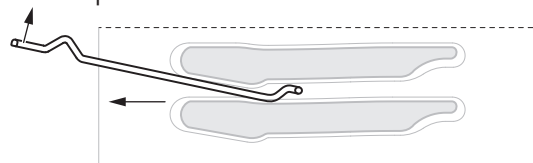


To remove oven rack from the oven:

1. Pull rack forward

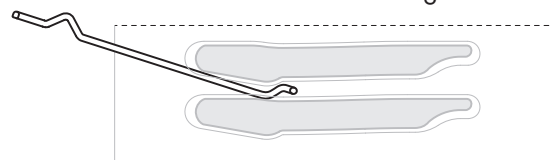


2. Lift rack up at front and then remove it

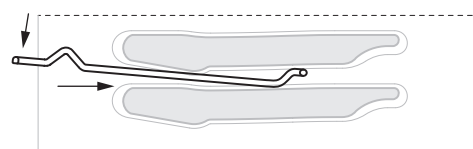


To replace an oven rack:

1. Place rear of rack between rack level guides



2. While lifting front of rack, slide rack in all the way while lowering the front



Oven Extendable Racks

- The extendable rack allows for easier access to cooking foods. It extends beyond the standard flat rack bringing the food closer to the user.

CAUTION

When the rack is outside of the oven, slide arms do not lock. They could unexpectedly extend if the rack is carried incorrectly.

Extending slide arms could cause injury. Rack should only be held or carried by grasping the sides.

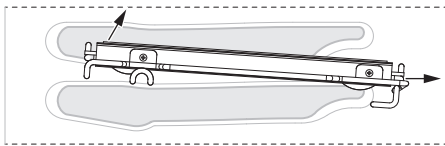
NOTE: Always remove the extendable rack before self-cleaning the oven.

CAUTION

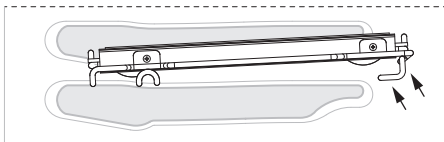
To avoid burns, pull rack all the way out and lift pan above handle when transferring food to and from oven.

To remove extendable rack from the oven:

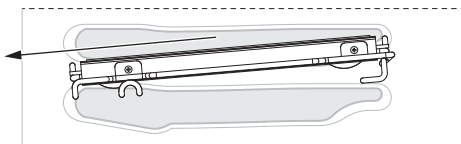
1. Lift of rack slightly and push it until the stop release



2. Raise back of rack until frame and stop clear rack guide

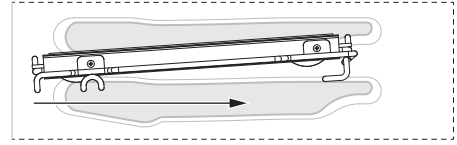


3. Pull rack down and out

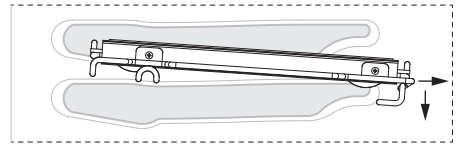


To replace an extendable rack:

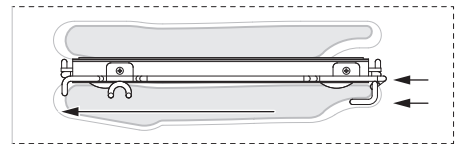
1. Grasp rack firmly on both sides. Place rack (including frame) above desired rack guide



2. Push all the way in until the back of the rack drops into place



3. Pull both sections forward until stops activates. Rack should be straight and flat, not crooked



Instruction for initial switch-on

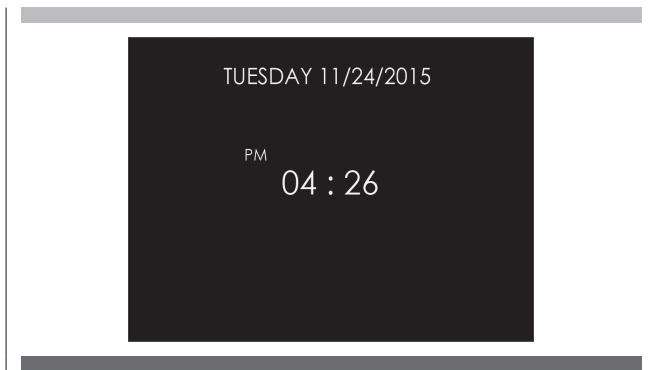
Once the range has been connected to the power supply for the first time, the control automatically prepares for setting a number of user settings, which remain stored in case of any subsequent switch-on.


NOTE: Both at the first and subsequent connections to the power supply, the door lock mechanism performs a calibration run - **in this phase, always keep the door closed.**

- Language
- Temperature&Weight
- Time
- Data

Refer to the USER SETTING paragraph for setting instructions.

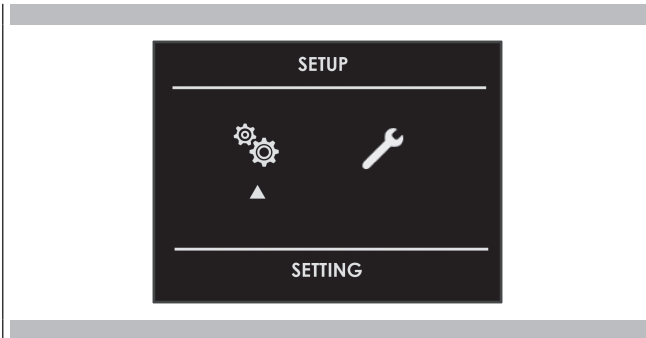
After making the user settings, the control moves automatically to the "Standby" display page.



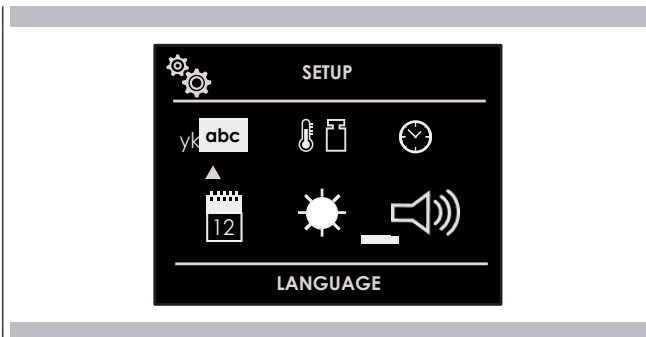
With the oven on, select the  icon and confirm with the function knob to enter the SETTINGS menu. This menu permits personalizing the settings of your oven. To make access, no active cooking or any set time functions must be in progress.

NOTE: The Setting menu can never be set if any time function is already set: first delete all the active time functions.

1. Rotate the [FUNCTION] knob to select the sub menu and confirm by means of pressing the [FUNCTION] knob.



2. Use this menu to change the following settings:
 Rotate the [FUNCTION] knob to select the setting or change a sub menu from among the six available ones and confirm by means of pressing the [FUNCTION] knob.



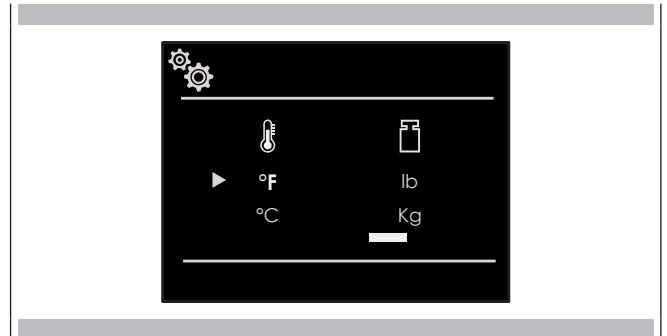
Language

Rotate the [FUNCTION] knob to select a language from among those available, and confirm by means of pressing the [FUNCTION] knob.



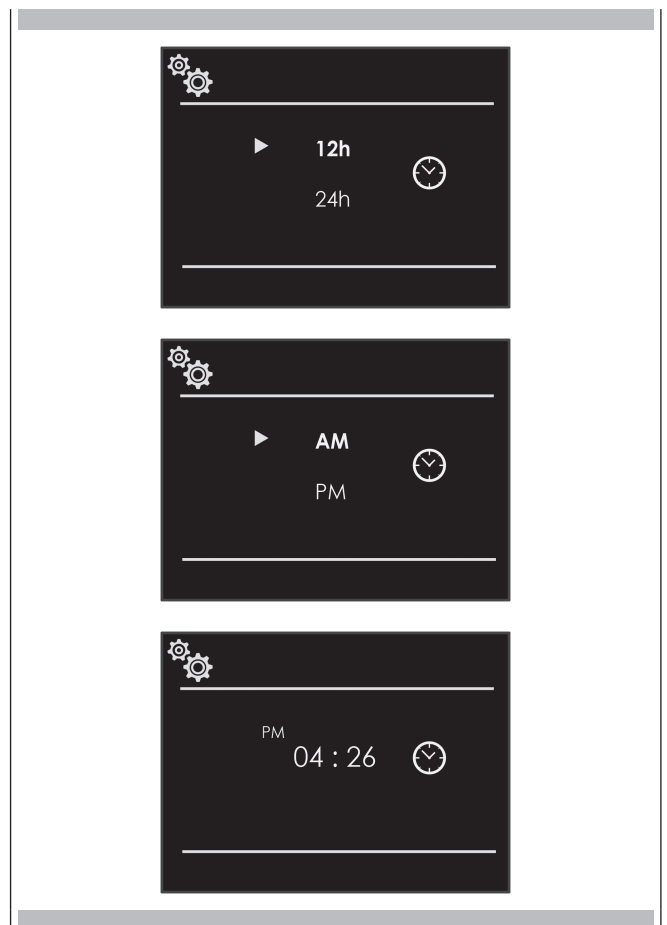
Temperature & Weight

Rotate the [FUNCTION] knob to select one of the two temperature options "C/ F" or weight options Kg/lb and confirm by means of pressing the [FUNCTION] knob.



Time

Rotate the [FUNCTION] knob to select the time format between the options "12h AM/PM or 24h" and confirm by means of pressing the [FUNCTION] knob. Subsequently, set the time of the day using the same procedure.



Date

Rotate the [FUNCTION] knob to select the date format from among the options “D.M.Y. – Y.M.D. – M.D.Y.” and confirm by means of pressing the [FUNCTION] knob.



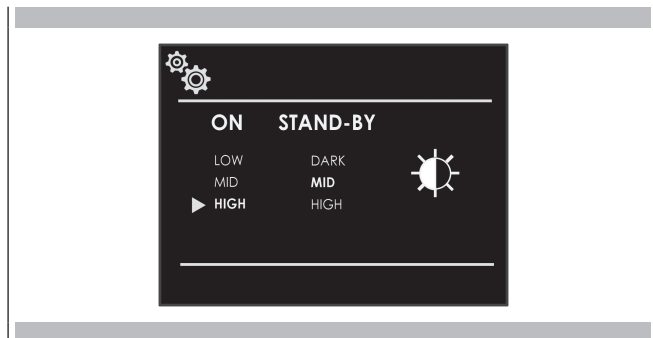
Beeper


Rotate the [FUNCTION] knob to select the required beep level and confirm by means of pressing the [FUNCTION] knob.



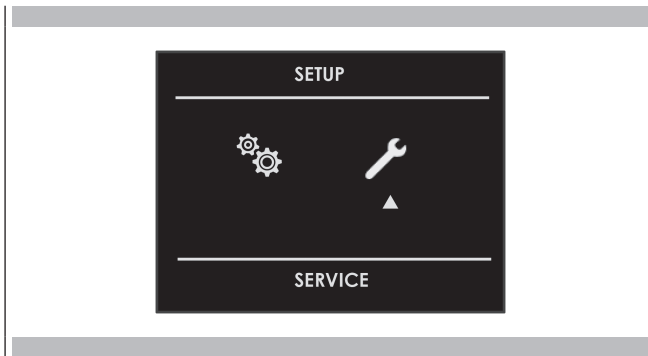
Brightness

Rotate the [FUNCTION] knob to choose which luminosity setting to change between ON or STANDBY, then by means of rotating the [FUNCTION] knob to select the required degree of luminosity and confirm by means of pressing the [FUNCTION] knob.

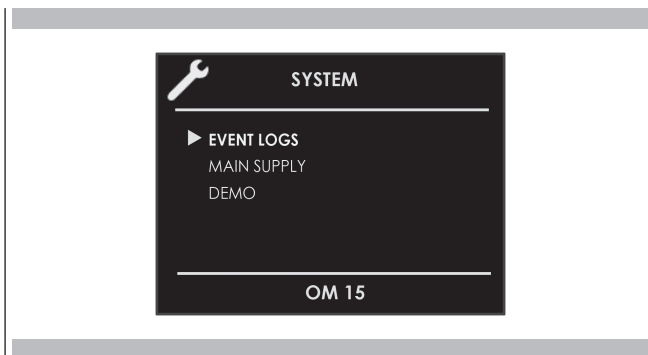


With the oven on, select the icon  and confirm with the [FUNCTION] knob to enter the SETTINGS menu. This menu permits setting a number of parameters or special functions. It also permits accessing the error events list.

1. Press the [FUNCTION] knob to select the sub menu and confirm by means of pressing the [FUNCTION] knob.

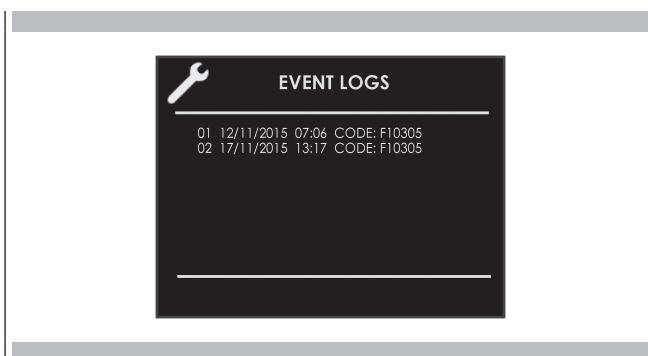


2. Use this menu to change the following settings: Press the [FUNCTION] knob to select the item to be set or to be displayed from among the three available ones and confirm by means of pressing the [FUNCTION] knob.



Event Log

The menu permits checking any recorded errors. These codes can be notified to the after-sales service.



Demo

The purpose of this function is to set the DEMO mode, which makes the oven useless for cooking but automatically performs a demonstration of functions.

1. Press the [FUNCTION] knob to select the item ON.
2. Confirm by means of pressing the [FUNCTION] knob.
3. Press the [ON/OFF] knob.

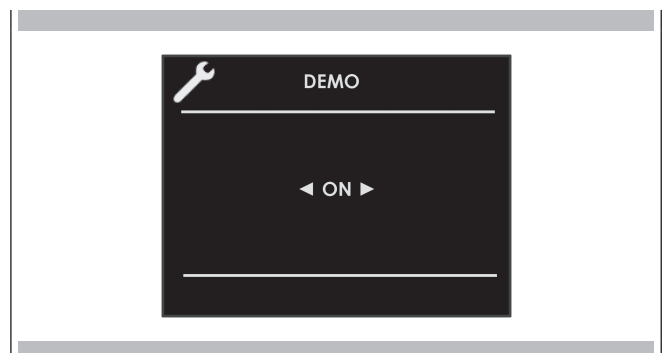
After about 30 seconds, the oven starts to operate in this mode.

To temporarily stop the DEMO function, simply keep any knob pressed for a few second until the oven switches to standby.

To start it again, press the [ON/OFF] knob.

To disable the function, enter the DEMO display page and set OFF. Confirm by means of pressing the [FUNCTION] knob.

NOTE Once set, the function remains enabled even if the oven is disconnected from the power mains.



Switching the oven on and off

IMPORTANT









- After switching off the oven, the cooling fan could continue to operate until the inner parts of the oven have cooled down.

Press the [ON/OFF] knob to switch the oven ON and press again to switch it OFF. The oven returns to standby mode.






Selecting the cooking mode

IMPORTANT

- Do not leave the door open for a long time during cooking.
- The door must be kept closed during the BROIL functions.
- Position the grill or grills on an appropriate level.

Functions	
	BAKE
	ROAST
	TRUE CONVEC.
	CONVEC. ROAST
	CONVEC. BAKE
	ECO BAKING
	BROIL
	CONVEC. GRILL
	CONVEC. BROIL
	PIZZA
	CLASSIC PIZZA (On some models)
	DEFROST

Functions

	DEHYDRATE
	WARM
	WARM PLUS
	SABBATH (On some models)
	SELF CLEAN

Select the appropriate cooking mode according to the food to be cooked using the [FUNCTION] knob and confirm by means of pressing the [FUNCTION] knob.

Changing the cooking mode












To change the cooking mode while the oven is working, rotate [BACK] for 2 seconds. At this point, another cooking mode can be selected from among those available in the group by means of the [FUNCTION] knob.

Changing temperature

IMPORTANT

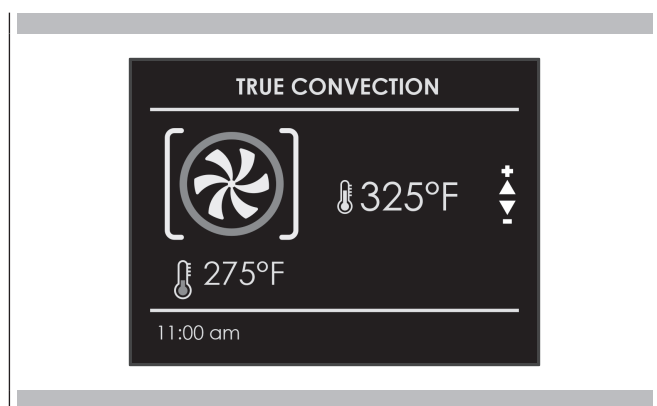
- The BROIL function operates at levels. No temperature can be set because this works at fixed cycles according to the set level from L1 to L5.
- The maximum temperature of the BROIL function is limited according to the set level.
- In all the cooking modes where the temperature is fixed, this is not shown on the screen.
- At the end of a function, the display screen shows the residual compartment heat temperature from the standby page.

1. From the cooking mode display page, the temperature can be changed by means of the [TEMPERATURE] knob.
2. Once cooking has started, the temperature can in any case be changed, at any time, by means of the [TEMPERATURE] knob.

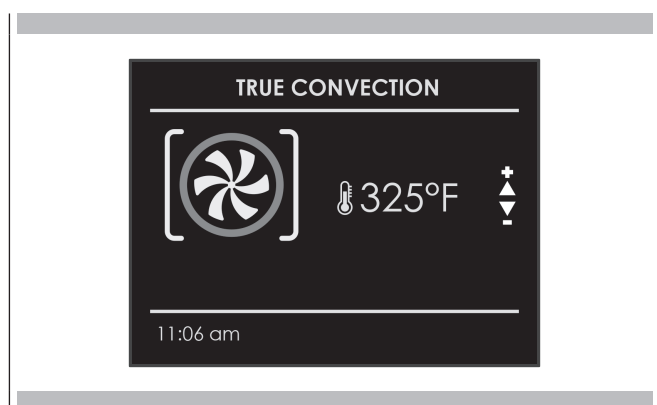
COOKING MODE	ICON	FAST PREHEAT	MEAT PROBE	TEMPERATURE		
				Min.	Preset	Max.
DEFROST				***	***	***
DEHYDRATE				120 F (50 C)	140 F (60 C)	160 F (70 C)
WARM				85 F (30 C)	105 F (40 C)	120 F (50 C)
WARM PLUS				130 F (55 C)	165 F (75 C)	210 F (100 C)
BAKE		⋈		165 F (75 C)	345 F (175 C)	550 F (290 C)
ROAST		⋈		165 F (75 C)	345 F (175 C)	550 F (290 C)
ECO BAKING				165 F (75 C)	330 F (165 C)	550 F (290 C)
TRUE CONVECTION		⋈		165 F (75 C)	330 F (165 C)	550 F (290 C)
PIZZA		⋈		165 F (75 C)	330 F (165 C)	550 F (290 C)
CONVECTION ROAST		⋈		165 F (75 C)	330 F (165 C)	550 F (290 C)
CONVECTION GRILL		⋈		165 F (75 C)	330 F (165 C)	550 F (290 C)
CONVECTION BAKE		⋈		165 F (75 C)	445 F (230 C)	550 F (290 C)
CONVECTION BROIL		⋈		165 F (75 C)	445 F (230 C)	550 F (290 C)
BROILL1					375 F (190 C)	
BROILL2					400 F (205 C)	
BROILL3					430 F (220 C)	
BROILL4					450 F (235 C)	
BROILL5					480 F (250 C)	
CLASSIC PIZZA (if present)					650 F (345 C)	
SABBATH (if present)				140 F (60 C)	140 F (60 C)	550 F (290 C)
SELF CLEAN					860 F (460 C)	

Pre-heating phase

While the oven is in pre-heating phase, the instantaneous temperature is displayed underneath the cooking mode icon.



Just as soon as the set temperature is reached, an acoustic signal is heard and the instantaneous temperature indication disappears.



Eco

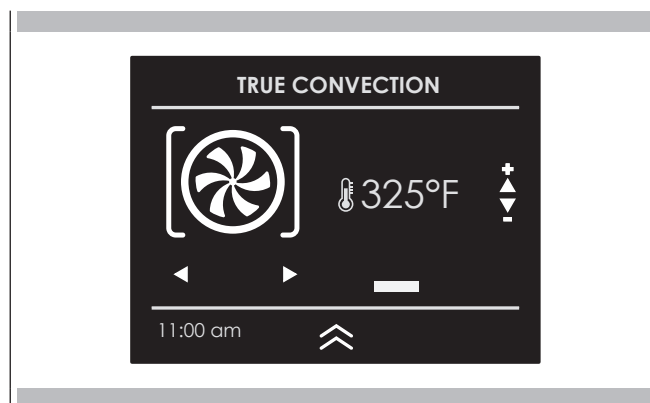
This mode is intended to save energy. Ideal for frozen or precooked food, and small portions-meals. The preheat time is very short and cooking tends to be slower. It is not recommended for heavy loads e.g. large portions or big meal preparation.

Fast Preheat

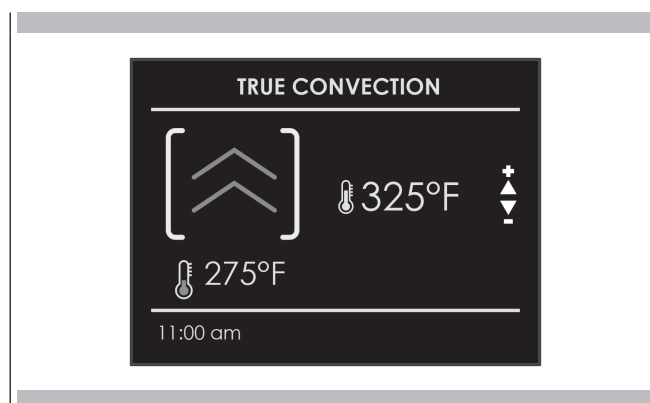
The FAST PREHEAT function permits reaching the desired temperature quicker compared to standard preheating. The function can be enabled for all the cooking modes in the BAKE (except the Sabbath and ECO), CONVECT and PIZZA groups.

To select FAST PREHEAT:

1. Select and start the cooking mode and turn the knob to the RIGHT.
2. After entering the functions menu, select the icon by means of the knob and confirm by means of the pressing [FUNCTION] knob. The symbol appears in the lower part of the screen.



3. The display page shows the icon of the active functions until the set temperature has been reached. Afterwards, the function switches to automatic in the selected cooking mode.



Using Oven Lights

A single push of the [FUNCTION] knob activates the lights only when pressed during a cooking operation. Oven lights turn on automatically when the door is opened. When an oven is in use, oven lights turn on automatically when a mode is started. Oven lights will turn off automatically when the oven mode is cancelled.

NOTE: The lights do not operate in the Self-Clean mode.

NOTE: Once switched on, the lights go OFF automatically after 3 minutes. To switch them back ON, press the [FUNCTION] knob or open the door.

Be sure that the time-of-day clock is displaying the correct time.
The timed mode turns off the oven at the end of the cook time.

CAUTION



Never leave food in the oven for more than one hour before and after cooking.
This could deteriorate the properties of the food itself.

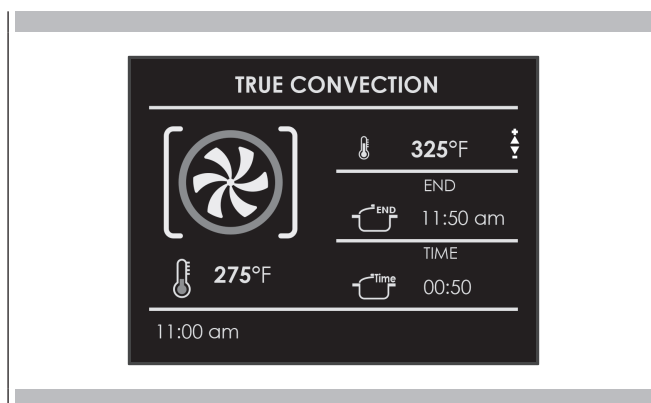
NOTE The time functions cannot be used if the meat probe is on. The maximum cooking time that can be set is 12 h.

Cook Time

Use the "Cook Time" function to operate the oven for a determinate period of time. The oven starts immediately and switches off automatically once the time has expired.

To Set a Timed Mode

1. Select the cooking mode and temperature.
2. There are two ways to set the function.
 - a) Select  to set the duration and press [FUNCTION] knob.
 - b) Select  to set the stop time and press [FUNCTION] knob.
3. After selecting one of the two above options, set the time by means of the [FUNCTION] knob and confirm and confirm by means of the pressing [FUNCTION] knob.
4. After pressing the [FUNCTION] knob cooking starts and the time cooking information is shown on the display page.
 - Cooking mode
 - Temperature
 - Cooking time
 - End of cooking time




- 5 After cooking, the oven switches off and an acoustic signal warns that cooking has terminated.

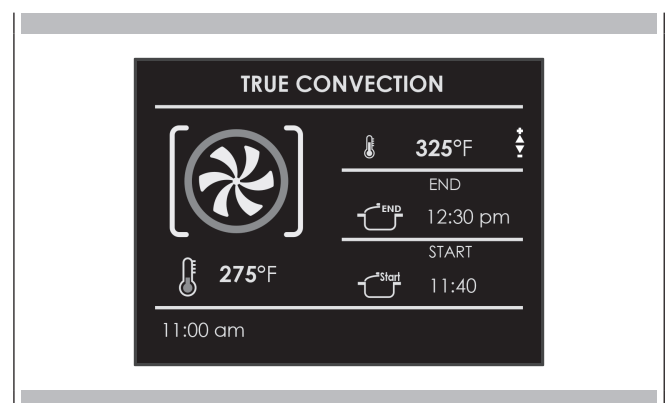
To change the cooking time when the oven is already operating, simply rotate the [FUNCTION] knob to the right [LOCK] and enter the new cooking stop time before pressing the [FUNCTION] knob again.

Stop Time

Use the "Stop Time" function to delay the start of timed cooking. Enter the cooking stop time and the oven will automatically calculate the start time. The oven switches on and off automatically.

To Delay the Start of a Timed Mode

- 1 First of all set the required timed cooking as indicated in the "COOK TIME" paragraph.
- 2 Select  to set the stop time and press [FUNCTION] knob.
- 3 Set the cooking stop time by means of the [FUNCTION] knob and confirm and confirm by means of the pressing [FUNCTION] knob.
- 4 After pressing the [FUNCTION] knob, the function positions in standby and the postponed cooking details are shown on the screen.
 - Cooking mode
 - Temperature
 - Cooking stop time
 - Cooking start time



- After cooking, the oven switches off and an acoustic signal warns that cooking has terminated.

To change the cooking time and stop time when the oven is already operating, simply rotate the [FUNCTION] knob to the right [LOCK] and enter the new cooking stop time before pressing the [FUNCTION] knob again.

When roasts, steaks or poultry are being cooked, this is the best way to tell when the food is correctly cooked.

This oven is optionally provided with the meat probe feature to sense the temperature inside meat and stop cooking as soon as the set value is reached.

When the probe is used, the oven automatically checks the cooking time.

NOTE : the food probe is an accessory available only in some versions of the product.

Tenderness, aroma and flavour are the result of precise, functional control.

The food probe is a thermometer which, when inserted into the food, makes it possible to check the internal temperature and use it to establish the end of cooking.

For example, meat may look like it is cooked on the outside, but still be pink on the inside!

The temperature reached by food during cooking is closely linked to problems relating to health and hygiene. Bacteria can be contained in every kind of meat, poultry and fish, as well as raw eggs.

Certain types of bacteria make food go off, while others, such as Salmonella, Campylobacter jejuni, Listeria monocytogenes, Escherichia coli and Staphylococcus aureus can be seriously harmful to human health. Bacteria multiply very quickly above a temperature of 4.4 up to 60 C. Mince is particularly at risk from this point of view.

To prevent bacteria from multiplying, it is necessary to take the following measures:

- Do not defrost food at room temperature, always in the fridge or in the oven using the specific function. In the latter case, cook the food immediately afterwards.
- Stuff chicken just before eating it. Never buy pre-packed ready-stuffed chicken and only buy ready-cooked stuffed chicken when you intend to eat it within 2 hours.
- Marinate food in the fridge, not at room temperature.
- Use a food probe to check the temperature of meat, fish and poultry if they are more than 5 cm thick, to ensure that the minimum cooking temperatures are reached.
- The greatest hazards are posed by poorly cooked chicken, particularly at risk from Salmonella.
- Avoid interrupting the cooking process, i.e., partially cooking food, storing it and completing the cooking process later. This sequence encourages the growth of bacteria due to the "warm" temperatures reached inside the food.
- Roast meat and poultry in the oven at temperatures of at least 165 C.

NB: Use only the meat probe supplied with the appliance.

In any case, we recommend that you consult the following table taken from the National Food Safety Database (USA).

Food	Minimum internal temperature
Mince	
Hamburger	71 C
Beef, veal, lamb, pork	74 C
Chicken, turkey	74 C
Beef, veal, lamb	
Roasts and steaks:	
Rare	The cooking temperature for rare meat is not indicated by the NFSD as it is unsafe for health reasons
Medium-rare	63 C
Medium	71 C
Well done	77 C
Pork	
Chops, roasts, ribs:	
Medium	71 C
Well done	77 C
Fresh ham	71 C
Fresh sausages	71 C
Poultry	
Whole chicken or chicken pieces	82 C
Duck	82 C
Whole turkey (not stuffed)	82 C
Turkey breast	77 C


WARNING

- To avoid burns, use a kitchen glove to fit and remove the meat probe when the oven is hot.
- Always remove the probe using the grip. If it is removed by pulling the cable, it could suffer damage.
- Make sure the food is completely de-frozen when the probe is fitted. Otherwise it could suffer damage.

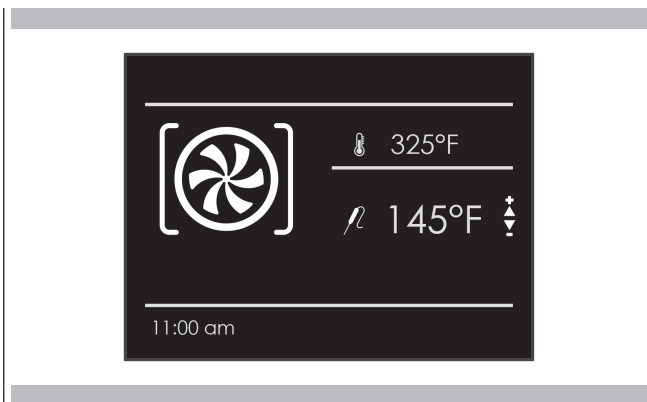
NOTE The meat probe is not enabled for all functions (meat probe function not available also for Recipes). If it is fitted during one of these functions, a probe removal message appears on the screen.
If the meat probe is accidentally removed during operation, a warning message appears on the screen.
The temperature of the probe can be set between 104 F and 212 F (40 C - 100 C).
The oven stores the last temperature set by the user.

Insert the tip of the probe in the central and thickest part of the meat.

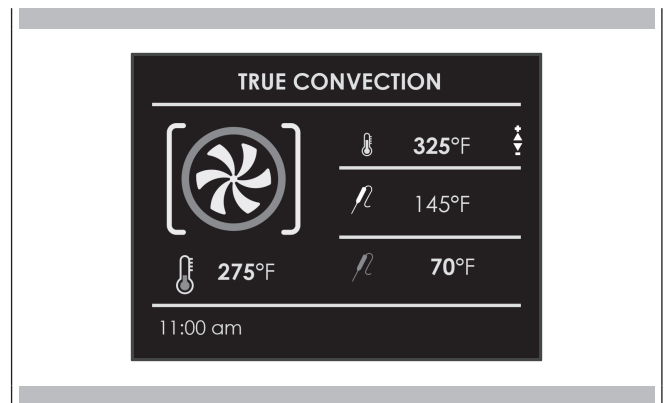
Make sure the probe is not in contact with the fat, bone, oven parts or dishes.

The meat probe is automatically recognised when it is inserted and the icon  appears on the screen.

When a cooking mode is started with the probe inserted, the display page for setting the function appears automatically.



1. Set the required probe temperature by means of the [TEMPERATURE] knob.



2. After pressing the [FUNCTION] knob the cooking starts and all probe cooking details appear on the screen.

- Cooking mode
- Oven temperature
- Set probe temperature
- Instantaneous probe temperature

Once the set probe temperature is reached, the oven switches off and an acoustic signal warns that cooking has terminated.

NOTE: After cooking has started, the oven temperature can in any case be changed at any time by means of the [TEMPERATURE] knob.

To change the probe temperature, turn the [FUNCTION] knob [BACK] for 2 seconds, then select again the cooking function and change the temperature value.

Roast Tips and Techniques

Roasting is cooking with heated air. Both upper and lower elements in the oven are used to heat the air but no fan is used to circulate the heat.

Follow the recipe or convenience food directions for baking temperature, time and rack position. Baking time will vary with the temperature of ingredients and the size, shape and finish of the baking utensil.

General Guidelines

- For best results, bake food on a single rack with at least 1" - 1 ½" (2,5 - 3cm) space between utensils and oven walls.
- Use one rack when selecting the bake mode.
- Check for doneness at the minimum time.
- Use metal bake ware (with or without a non stick finish), heatproof glass, glass-ceramic, pottery or other utensils suitable for the oven.
- When using heatproof glass, reduce temperature by 25 F (15 C) from recommended temperature.
- Use baking sheets with or without sides or jelly roll pans.
- Dark metal pans or nonstick coatings will cook faster with more browning. Insulated bake ware will slightly lengthen the cooking time for most foods.
- Do not use aluminum foil or disposable aluminum trays to line any part of the oven. Foil is an excellent heat insulator and heat will be trapped beneath it. This will alter the cooking performance and can damage the finish of the oven.
- Avoid using the opened door as a shelf to place pans.
- Tips for Solving Baking Problems are found on Page 58.

True Convection Tips and Techniques

- Reduce recipe baking temperatures by 25 F (15 C).
- For best results, foods should be cooked uncovered, in low-sided pans to take advantage of the forced air circulation. Use shiny aluminum pans for best results unless otherwise specified.
- Heatproof glass or ceramic can be used. Reduce temperature by another 25 F (15 C) when using heatproof glass dishes for a total reduction of 50 F (30 C).
- Dark metal pans may be used. Note that food may brown faster when using dark metal bake ware.
- The number of racks used is determined by the height of the food to be cooked.
- Baked items, for the most part, cook extremely well in convection. Don't try to convert recipes such as custards, quiches, pumpkin pie, or cheesecakes, which do not benefit from the convection-heating process. Use the regular Bake mode for these foods.
- Multiple rack cooking for oven meals is done on rack positions 1, 2, 3, and 4. All four racks can be used for

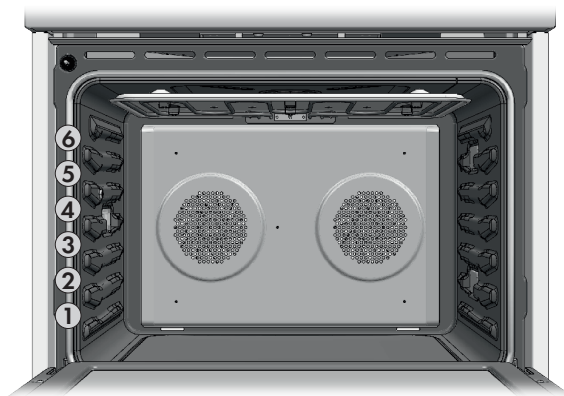
cookies, biscuits and appetizers.

- 2 Rack baking: Use positions 1 and 3.
- When baking four cake layers at the same time, stagger pans so that one pan is not directly above another. For best results, place cakes on front of upper rack and back of lower rack (See graphic at right). Allow 1" - 1 ½" (2,5 - 3cm) air space around pans.
- Converting your own recipe can be easy. Choose a recipe that will work well in convection.
- Reduce the temperature and cooking time if necessary. It may take some trial and error to achieve a perfect result. Keep track of your technique for the next time you want to prepare the recipe using convection.
- Tips for Solving Baking Problems are found on Page 58.

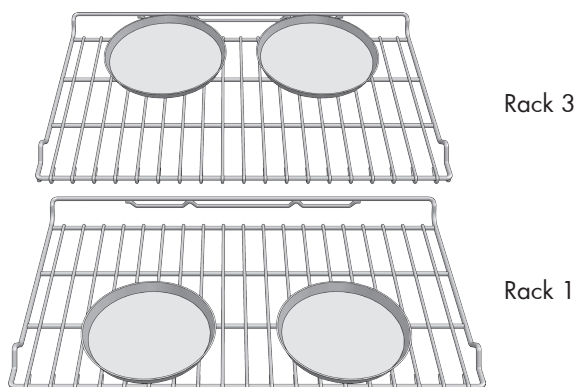
Foods recommended for Convection Bake mode:

Appetizers Biscuits Coffee Cakes
 Cookies (2 to 4 racks) Yeast Breads
 Cream Puffs
 Popovers
 Casseroles and One-Dish Entrées
 Oven Meals (rack positions 1, 2, 3)
 Air Leavened Foods (Soufflés, Meringue, Meringue-Topped Desserts, Angel Food Cakes, Chiffon Cakes)

RACK POSITION



MULTIPLE RACK PAN PLACEMENT



Quick and easy recipe tips

Converting from standard BAKE to CONVECTION BAKE:

Reduce the temperature by 25 F (15 C).

Use the same baking time as Bake mode if under 10 to 15 minutes.

Foods with a baking time of less than 30 minutes should be checked for doneness 5 minutes earlier than in standard bake recipes.

If food is baked for more than 40 to 45 minutes, bake time should be reduced by 25%.

Convection Roast Tips and Techniques

- Do not preheat for Convection Roast.
- Roast in a low-sided, uncovered pan.
- When roasting whole chickens or turkey, tuck wings behind back and loosely tie legs with kitchen string.
- Use the 2-piece broil pan for roasting uncovered.
- Use the probe or a meat thermometer to determine the internal doneness on "END" temperature.
- Double-check the internal temperature of meat or poultry by inserting meat thermometer into another position.
- Large birds may also need to be covered with foil (and pan roasted) during a portion of the roasting time to prevent over-browning.

Quick and easy recipe tips

Converting from standard **BAKE** to **CONVECTION ROAST**:

- Temperature does not have to be lowered.
- Roasts, large cuts of meat and poultry generally take 10-20% less cooking time. Check doneness early.
- Casseroles or pot roasts that are baked covered in **CONVECTION ROAST** will cook in about the same amount of time.
- The minimum safe temperature for stuffing in poultry is 165 F (75 C).
- After removing the item from the oven, cover loosely with foil for 10 to 15 minutes before carving if necessary to increase the final foodstuff temperature by 5 to 10 F (3 to 6 C).

Cooking times are indicative and also depend on the thickness and the starting temperature of the meat before cooking.

Convection Broil Tips and Techniques

- Place rack in the required position needed before turning on the oven.
 - Use Convection Broil mode with the oven door closed.
 - Do not preheat oven.
 - Use the 2-piece broil pan.
 - Turn meats once halfway through the cooking time (see convection broil chart).
- Broiling and convection broiling times are approximate and may vary slightly.

Cooking times are indicative and also depend on the thickness and the starting temperature of the meat before cooking.

Broil Tips and Techniques

- Place rack in the required position needed before turning on the oven.
- Use Broil mode with the oven door closed.
- Preheat oven for 5 minutes before use.
- Use the 2-piece broil pan.
- Turn meats once halfway through the cooking time (see convection broil chart).

Broiling and convection broiling times are approximate and may vary slightly.

Cooking times are indicative and also depend on the thickness and the starting temperature of the meat before cooking.

Dehydrate Tips and Techniques

Dehydrating can be done using the Dehydrate mode.

A lower temperature is used and the circulating heated air slowly removes the moisture for food preservation.

The Dehydrate mode temperature is pre-programmed at 140°F (60°C).

The Dehydrate mode temperatures available are 120°F (50°C) to 160°F (70°C).

Multiple racks can be used simultaneously.

Some foods require as much as 14-15 hours of time to fully dehydrate.

Consult a food preservation book for specific times and the handling of various foods.

This mode is suitable for a variety of fruits, vegetables, herbs and meat strips.







Drying screens can be purchased at specialty kitchen shops.

By using paper towels, some food moisture can be absorbed before dehydrating begins (such as with sliced tomatoes or sliced peaches).


Dehydrate Chart

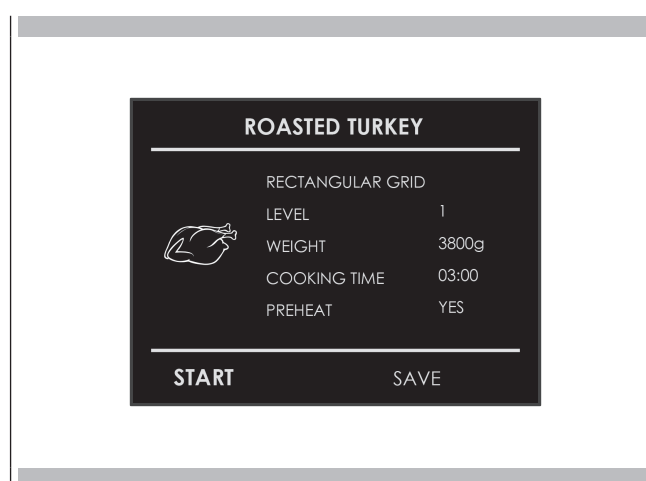
FOOD	PREPARATION	APPROXIMATE DRYING TIME* (hrs)	TEST FOR DONENESS
FRUIT			
Apples	Dipped in 1 cup lemon juice and 2 cups water, slices	11 - 15	Slightly pliable
Bananas	Dipped in 1 cup lemon juice and 2 cups water, slices	11 - 15	Slightly pliable
Cherries	Wash and towel dry. For fresh cherries, remove pits	10 - 15	Pliable, leathery, chewy
Oranges Peels and slices	slices of orange; orange part of skin thinly peeled from oranges	Peels: 2 - 4	Orange peel: dry and brittle
		Slices: 12 - 16	Orange slices: skins are dry and brittle, fruit is slightly moist
Pineapple rings	Towel dried	Canned: 9 - 13 Fresh: 8 - 12	Soft and pliable
Strawberries	Wash and towel dry. Sliced 1/2" thick, skin (outside) down on rack	12 - 17	Dry, brittle
VEGETABLE			
Peppers	Wash and towel dry. Remove membrane of pepper, coarsely chopped about 1" pieces	16 - 20	Leathery with no moisture inside
Mushrooms	Wash and towel dry. Cut of stem end. Cut into 1/8" slices	7 - 12	Tough and leathery, dry
Tomatoes	Wash and towel dry. Cut this slices, 1/8" thick, dry well	16 - 23	Dry, brick red color
HERBS			
Oregano, sage parsley and thyme, and fennel	Rinse and dry with paper towel	Dry at 120 F (60 C) 3 - 5	Crisp and brittle
Basil	Use basil leaves 3 to 4 inches from top. Spray with water, shake off moisture and pat dry	Dry at 120 F (60 C) 3 - 5	Crisp and brittle

The Recipe function of your oven gives you the chance to cook food without having to set the oven manually every time. By selecting a "SET" recipe, the cooking mode, the temperature and the time are automatically set according to the recipe selected from the menu.

Recipe List	Type of Food	Food condition	Recipes List	Information displayed
PRESET OR PERSONAL		FRESH	BREAD PIZZA FIRST	TYPE OF ACCESSORY LEVEL POSITION FOOD WEIGHT COOKING TIME PREHEAT REQUIRED (YES/NO)
		FROZEN		
		WHOLE	MEAT	
		IN PEICES		
		WHOLE	POULTRY	
		IN PEICES		
		WHOLE	FISH	
		IN PEICES		
		-	VEGETABLES	
		-		
		-	PIES	
		-		

Select an already-set recipe:

1. Switch the oven, select the icon  and press the [FUNCTION] knob.
2. Using the [FUNCTION] knob select the list between "PRESET" or "PERSONAL" and confirm by means of the same knob.
3. Choose the type of food to be cooked using the [FUNCTION] knob and confirm by means of the same knob.
4. Using the [FUNCTION] knob choose between "FRESH" or "FROZEN" or in other cases between "WHOLE" or "IN PEICES" and confirm by means of the same knob.
5. Select the required recipe by means of the [FUNCTION] knob and confirm by means of the same knob.
6. When the recipe is selected, the following display page appears on the screen:



7. To start the recipe, confirm by pressing the [FUNCTION] knob.

During a recipe, a number of acoustic and visual messages will ask you to perform the following operations. Simply follow the instructions on the screen.

8. Upon termination, the oven switches off and an acoustic and visual signal warns that the recipe has terminated.

Saving a personalized recipe:

Once a recipe has been selected, the "Time" and "Weight" setting can be changed and the recipe can be saved among the "PERSONAL" ones.

1. Once a recipe has been selected, rotate the [FUNCTION] knob and confirm by pressing the same knob.
2. To change the weight, enter the desired weight by means of the [FUNCTION] knob and confirm by pressing the same knob.



3. The oven switches automatically to the cooking time. To change this time, use the [FUNCTION] knob to set the cooking time and confirm by pressing the same knob.



4. At this point, the recipe can be saved in the list of "PERSONAL" recipes by selecting "SAVE" and confirming by means of the [FUNCTION] knob.

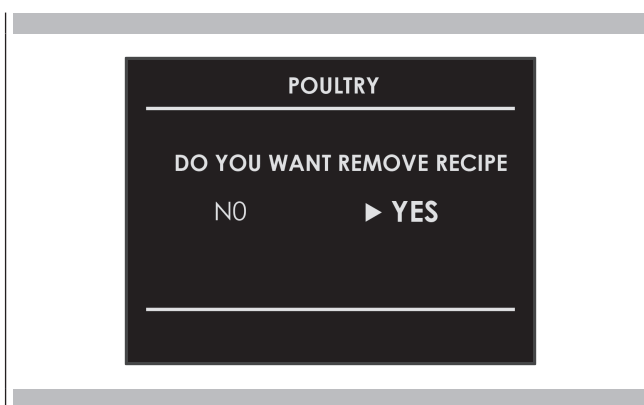



NOTE If the time and weight values are changed and not saved straight away, at the end of the recipe, a message appears which asks whether you want to save it.


5. To start the recipe press the [FUNCTION] knob.

Cancelling a Personalized recipe:

1. To eliminate a recipe from the list of personalized recipes, select the recipe.
2. Rotate the ON/OFF knob to the right and select the choice and confirm with the [FUNCTION] knob.




The CLASSIC PIZZA was specifically designed so you can bake perfect PIZZAS in just a few minutes. For perfect results, select the  to access this special recipe. After you make your settings, Classic Pizza recipes will do the rest, reaching about 650 F (345 C) by turning on the heating elements at 100% of their capacity. At this temperature, you are guaranteed to have a crispy base and proper cooking of the toppings of your pizza, like at the pizzeria. The secret to a good pizza is in the simplicity of a well-leavened dough, prepared and cooked well: use a small quantity of good quality toppings.

Recipe List	Type of Food	Food condition	Recipes List	Information displayed
PRESET OR PERSONAL		PIZZA SINGLE THIN	COOKING TIME PROPOSED	TYPE OF ACCESSORY
		PIZZA SINGLE THICK		LEVEL POSITION
		PIZZA DOUBLE THIN		COOKING TIME
		PIZZA DOUBLE THICK		PREHEAT REQUIRED YES/NO

Pizza	Weight Leavened Dough	Diameter
THIN	180 gr	30 cm
THICK	260 gr	30 cm

Selecting an already-set "CLASSIC PIZZA" recipe:

1. Start the oven and select the icon  and confirm with the [FUNCTION] knob.
2. By means of the [FUNCTION] knob, select the list between "PRESET" or "PERSONAL" and confirm with the same knob.
3. Choose the type of pizza to be cooked by means of the [function] knob and confirm by pressing the same knob.
4. After the recipe has been selected, the following display page appears:



Once a recipe has been selected the "Time" setting can be changed (from 01:00 min/sec to 59:59 min/sec) and the recipe can be saved among the "PERSONAL" recipes of the special Classic Pizza function. If so required, the saved recipe can also be cancelled.

If the time is changed and not immediately saved, at the end of the recipe, a message appears to

ask whether you want to save it.

(FOR MORE DETAILS ON HOW TO PERFORM THESE STEPS, REFER TO THE INSTRUCTIONS IN THE RECIPE PARAGRAPH).

5. Once confirmed with the [FUNCTION] knob, the oven preheats and when finished, it beeps and the display will tell that it's the right moment to put in the pizzas. Baking automatically starts when you close the door and, from now to the end, there are no other settings or anything to turn on; you must simply follow the instructions on the display.



NOTE After the first pizza, you can immediately continue baking other pizzas without having to preheat. If, on request is selected, the recipe is repeated, while if OFF is pressed the recipe terminates.

Tips For A Good Pizza:

Given the high temperatures and short baking time, we recommend that you insert and remove the pizzas quickly so that the door is open for as short a time as possible and the temperature doesn't drop.

Once the beep and display indicate that baking is finished, immediately remove the pizza, since the cooking times are very short and even a few seconds can have a significant effect.

The baking time can be changed based on the type of dough and pizza; changes should be made with the +/- knob before pressing the start knob.

At the end of the recipe, you will be asked if you want to save it in your personal recipes.

PIZZA GRILL**OVEN STONE (IF PRESENT)****Insert before the preheating the oven**

The Sabbath Mode function of your oven complied with Jewish laws. This function allows the oven to perform only the static function.

When the Sabbath function is selected, the following functions are disabled:

- Oven lights
- All the keys except ON/OFF and temperature setting
- Meat Probe Function
- Timed cooking function
- Timer function
- The icon on the display screen is steady and not animated as in the case of traditional cooking modes.
- Display screen and acoustic warnings.

To set the Sabbath Mode function, switch ON the oven and select the Sabbath function by means of the [FUNCTION] knob and confirm with the same knob.

The function starts by showing the icon on the display screen.



NOTE The function lasts at most 72 hours.

The temperature can be set at any time from 120 F (50 C) to 550F (290 C) with a preset of 140 F (60 C).

The function can be disabled at any time by pressing the OFF knob.

Abrasive detergents and steam cleaning equipment should not be used for cleaning.

⚠ WARNING

Do not use harsh abrasive cleaners or sharp metal scrapers to clean the oven door glass since they can scratch the surface, which may result in shattering of the glass.

⚠ WARNING

Ensure that the door is in the closed position before the self-cleaning cycle starts, otherwise automatic door locking will not be completed. See paragraphs that follows.

Self-Cleaning the Oven

This oven features a pyrolytic self-cleaning function that eliminates the difficult and time consuming manual scrubbing of the oven interior. During self-cleaning, the oven uses a very high temperature (approx. 860 F/460 C) to burn away food soil and grease.

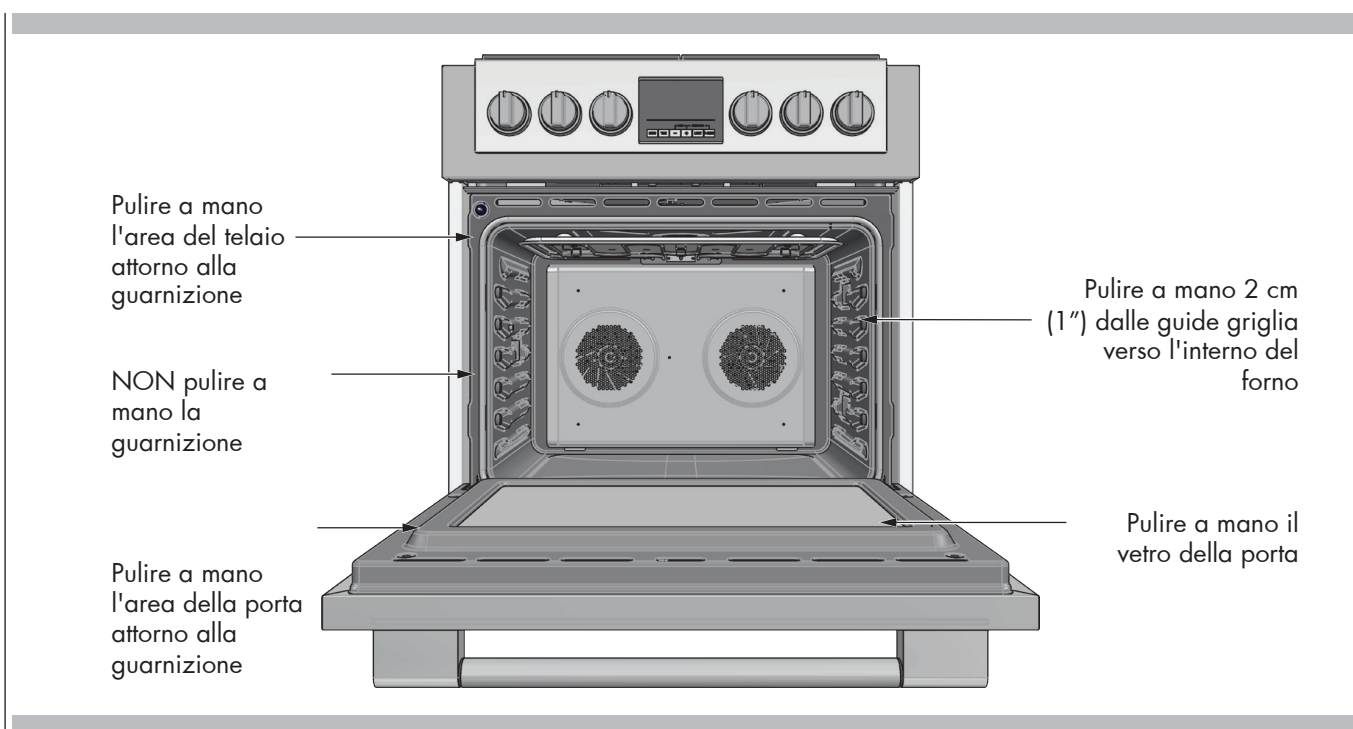
- Do not use the cooktop during the oven self cleaning cycle.
- Only one oven at a time can be set to Self-Clean.
- It is common to see smoke and/or an occasional flame-up during the Self-Clean cycle, depending on the content and amount of soil remaining in the oven. If a flame persists,
- turn off the oven and allow it to cool before opening the door to wipe up the excessive food soil.
- The door latch is automatically activated after selecting the Self-Clean cycle. The "PADLOCK" icon will appear in

the display. This ensures that the door cannot be opened while the oven interior is at clean temperatures.


- The oven light does not operate during this mode.
- During Self-Clean, the kitchen should be well ventilated to help eliminate odors associated with Self-Clean. Odors will lessen with use.
- Three hours is the preset length of cleaning.
- The mode automatically stops at the end of the clean hours.
- When the oven heat drops to a safe temperature, the automatic door lock will release and the door can be opened.

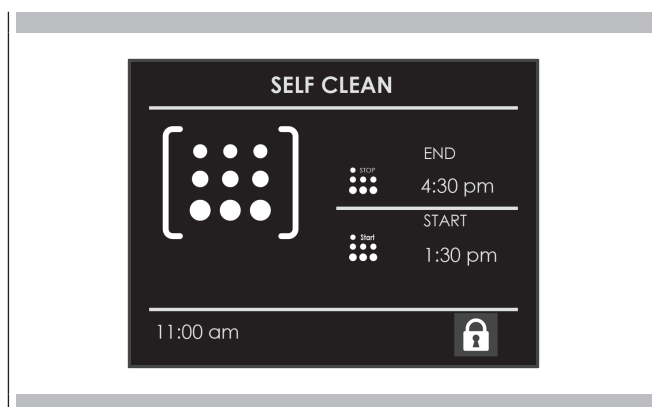
Preparing the Oven for Self-Clean

1. Remove all utensils and bake ware.
2. Remove non-porcelain oven racks. If chromed racks are left in the oven during the self-clean cycle, they will permanently lose the shiny finish and change to a dull dark finish.
3. Wipe up any soft soil spills and grease with paper towels. Excess grease will cause flames and smoke inside the oven during self-cleaning.
4. Review illustration below. Some areas of the oven must be cleaned by hand before the cycle begins. They do not get hot enough during the cleaning cycle for soil to burn away. Use a soapy sponge or plastic scrubber. Hand-clean the oven door edge, oven front frame and up to 1-½ " (2-3 cm) inside the frame with detergent and hot water. Do not rub the gasket on oven. Clean by hand the oven door window. Rinse all areas thoroughly then dry.
5. Be sure oven interior lights are turned off and the light bulbs and lens covers are in place.




To Set the Self-Clean Mode

1. Press the ON/OFF knob and select the icon  and then confirm with the same knob.
2. A message appears on the screen to remove all objects or accessories from the compartment.
3. Press the [FUNCTION] knob to start door lock and cleaning cycle.
4. The clean time is displayed automatically, its standard value is 3 hours.




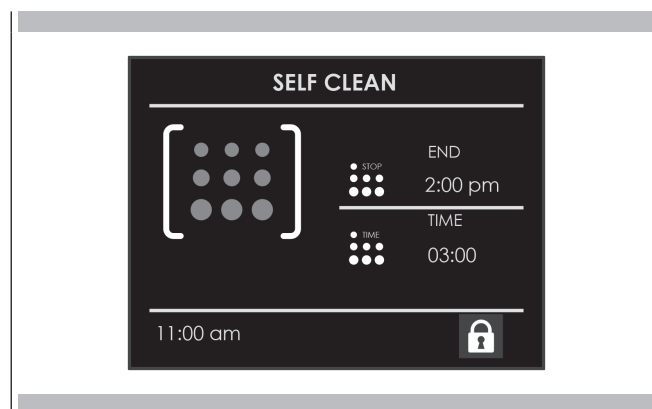
5. At the end of the programmed cleaning time, the oven will automatically turn off.
 - To stop the cleaning mode at any moment, press ON/OFF knob.
 - The Self Cleaning cycle cannot be selected if the door is open.
 - If the door is in the open position when the function has already been selected and the [FUNCTION] knob is pressed the latch doesn't move, the "PADLOCK" icon will flash until the door will be closed and the lock motor stops. When the "CLOSED PADLOCK" it is displayed, the door cannot be opened.
 - Check that the door has been locked, if door does not lock, press ON/OFF knob and do not start self-clean; phone for service.
 - Do not attempt to open the door while the cleaning cycle is running and the door is locked.

To Change the Cleaning Time

1. To change the setting from 3 hours, select either 2 hours for light soil immediately after starting.
2. To change the hours, rotate the [FUNCTION] knob to the RIGHT and select  icon, (the hours will flash), use the [FUNCTION] knob to change the value, than confirm by pressing the [FUNCTION] knob.
3. Automatically the minutes will flash, use the [FUNCTION] knob to change the value, than confirm by pressing the [FUNCTION] knob.

To Delay the Start of Cleaning

1. Follow steps 1 through 3 above.
2. Touch the  icon and verify that "STOP TIME" appears on the display. The hours will begin flashing, use the [FUNCTION] knob to change the value, than confirm by pressing the [FUNCTION] knob.
3. Automatically the minutes will flash, use the [FUNCTION] knob to change the value, than confirm by pressing the [FUNCTION] knob.



8. When the delay time expires, self-cleaning will start.
9. At the end of the programmed cleaning time, the oven will automatically turn off.

CAUTION

Keep in mind that the oven door will remain locked until it is safe enough to open. The lock symbol will disappear from the display when the door lock is released. You will still need to exercise caution when the door lock is released because the inside of the oven may still be hot.

After the self-clean cycle is complete the oven control monitoring the internal temperature and the following messages will be displayed:

- From the 460 C/860 F to 270 C/518 F= "End Self Cleaning"
- From the 270 C/518 F to 50 C/122 F= "Waiting to Clean"
- From the 50 C/122 F to 25 C/77 F= "Remove Residues" (Press ON/OFF key to clear the message).

You may notice a powder ash residue in the bottom of the oven after self-cleaning. This condition is normal. Use a damp cloth or sponge to wipe up the residue after the oven cools down.

Self-cleaning Tips:

If any soil remains in the oven after the self-clean cycle is complete, you may repeat the cycle if you want. Self-clean the oven regularly to prevent excessive soil build-up. Doing so will make the self-clean cycle work better and reduce smoke and odors.

⚠ ATTENTION

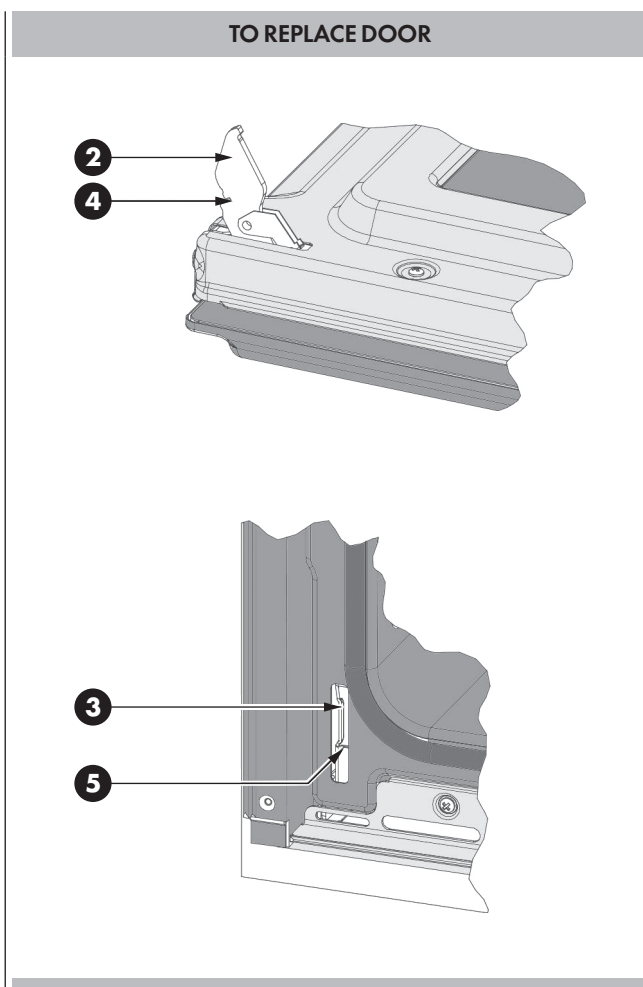
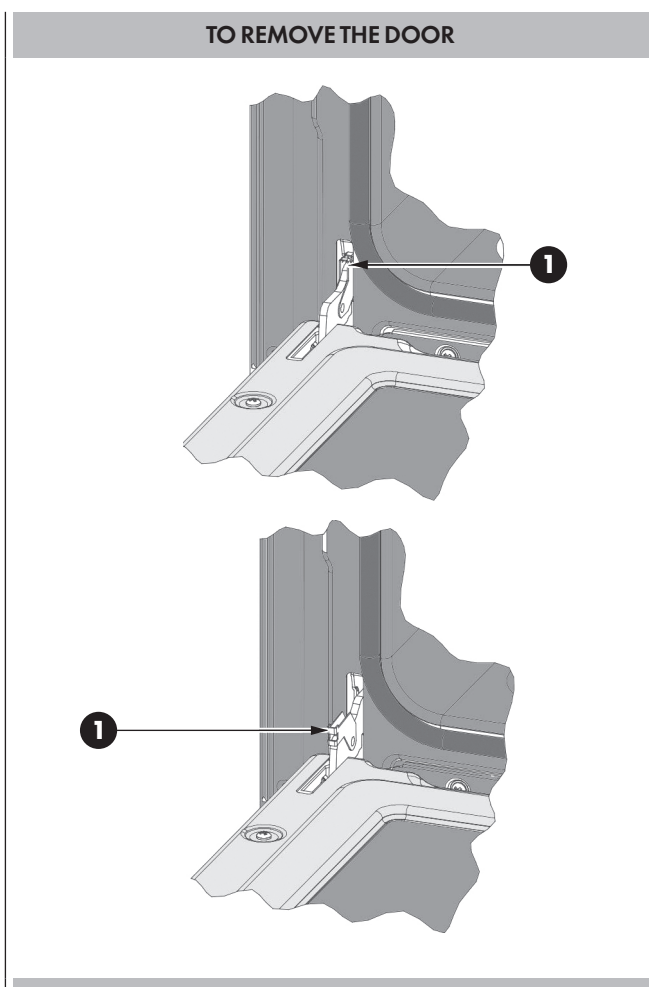
- Make sure oven is cool and power to the oven has been turned off before removing the door. Failure to do so could result in electrical shock or burns.
- The oven door is heavy and fragile. Use both hands to remove the oven door. The door front is glass.
- Handle carefully to avoid breakage.
- Grasp only the sides of the oven door. Do not grasp the handle as it may swing in your hand and cause damage or injury.
- Failure to grasp the oven door firmly and properly could result in personal injury or product damage.

To Remove Door

1. Open the door completely.
2. Flip the hinge security clip on each hinge towards you (1).
3. Hold the door firmly on both sides using both hands and close the door.
4. Hold firmly; the door is heavy.
5. Place the door in a convenient location.

To Replace Door

1. Insert the upper arms (2) of both hinges into the slots (3). The recesses (4) must hook on the lips (5).
2. Move the hinge security clips (1) back into position.
3. Close and open the door slowly to assure that it is correctly and securely in place.



- Each oven is equipped with three halogen lights located in the lateral walls of the oven.
- The lights are switched on when the door is opened or when the oven is in a cooking cycle.
- The oven lights are not illuminated during SELF- CLEAN.
- Each light assembly consists of a removable lens, a light bulb as well as a light socket housing that is fixed in place. See figure on this page.
- Light bulb replacement is considered to be a routine maintenance item.

To Replace a Light Bulb

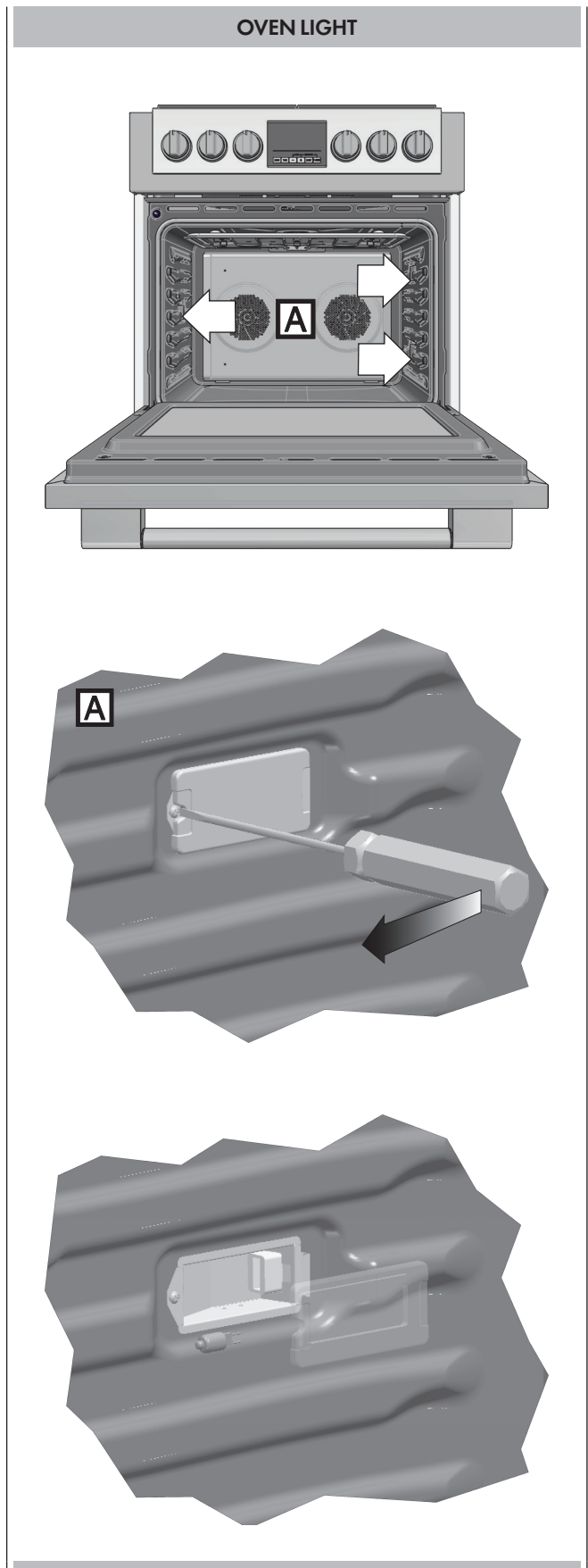
1. Read WARNING on this page.
2. Turn off power at the main power supply (fuse or breaker box).
3. Remove the lens between screw and glass using a screw driver.
4. Remove the light bulb from its socket by pulling it.
5. Replace the bulb with a new one. Avoid touching the bulb with fingers, as oils from hands can damage the bulb when it becomes hot.
6. The bulb is halogen: use one with the same type checking Voltage and Wattage.
7. Place the lens back on.
8. Replace the rack supports if provided is provided with the oven model.

Turn power back on at the main power supply (fuse or breaker box).

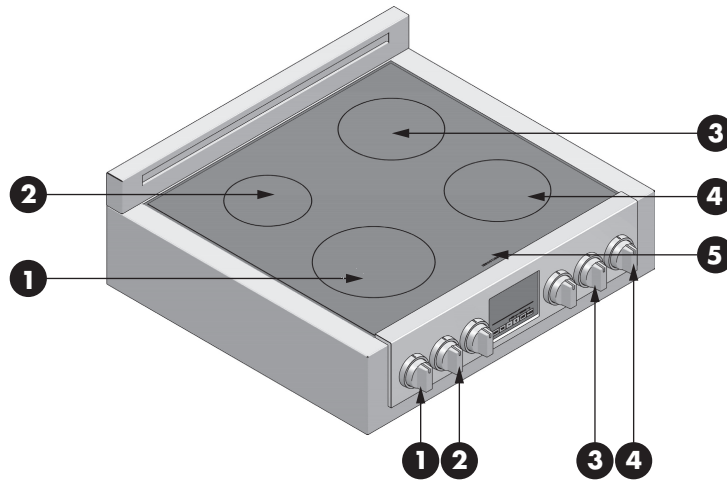


WARNING

- Make sure the oven and lights are cool and power to the oven has been turned off before replacing the light bulb(s). Failure to do so could result in electrical shock or burns.
- The lenses must be in place when using the oven.
- The lenses serve to protect the light bulb from breaking.
- The lenses are made of glass. Handle carefully to avoid breakage. Broken glass could cause an injury.

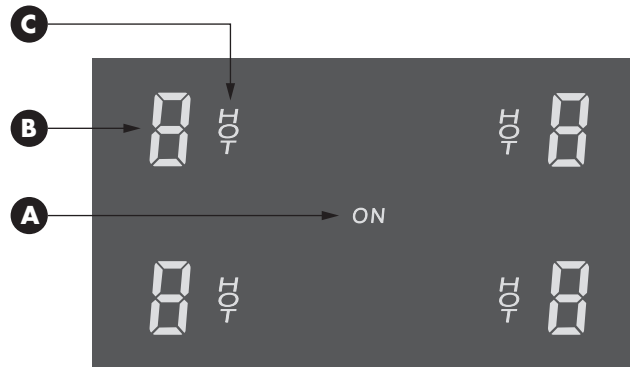


FEATURES OF YOUR COOKTOP 30"



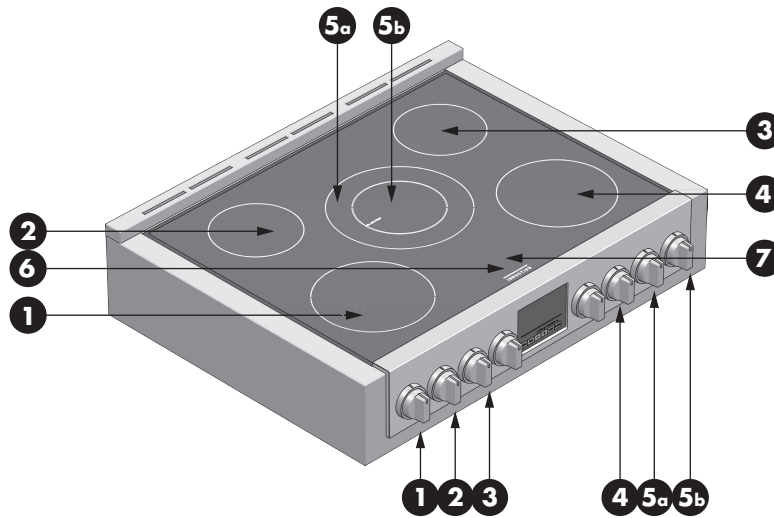
Position 1	2300W (Boost 3700W) 9" (230mm)	induction element and control
Position 2	1400W (Boost 2200W) 6" ½ (165mm)	induction element and control
Position 3	1850W (Boost 3000W) 7" (200mm)	induction element and control
Position 4	1850W (Boost 3000W) 7" (200mm)	induction element and control
Position 5	Led Display	

DISPLAY UNIT INDICATIONS



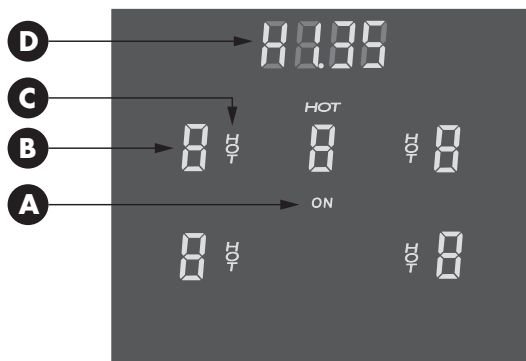
NOTE: power levels are indicative and can vary according to the pan used or the settings made.

FEATURES OF YOUR COOKTOP 36"

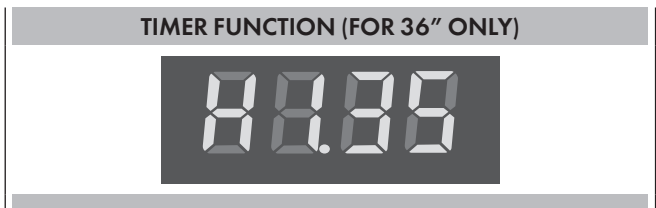
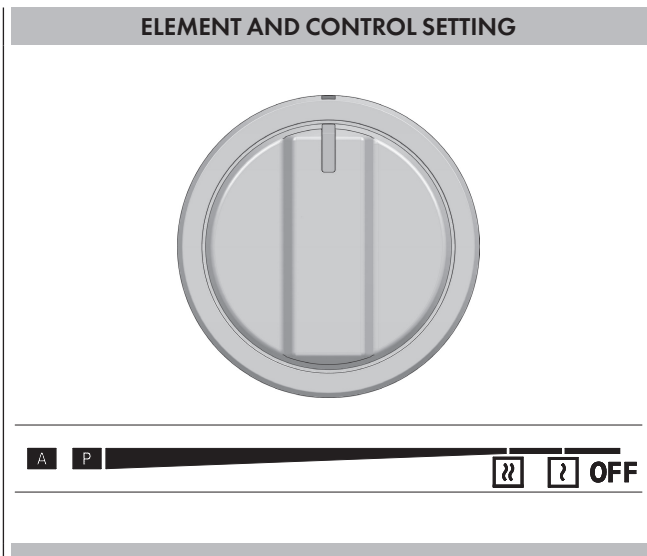


Position 1	2300W (Boost 3700W)	9"	(230mm)	induction element and control
Position 2	1850W (Boost 3000W)	7"	(180mm)	induction element and control
Position 3	1850W (Boost 3000W)	7"	(180mm)	induction element and control
Position 4	2300W (Boost 3700W)	9"	(230mm)	induction element and control
Position 5a	3000W (Boost 5500W)	11"	(280mm)	induction element and control
Position 5b	1850W (Boost 2600W)	7"	(180mm)	
Position 6	Led Display			
Position 7	Timer Display			timer control

DISPLAY UNIT INDICATIONS



NOTE: power levels are indicative and can vary according to the pan used or the settings made.



Timer function setting

NOTE: the timer is only intended as an acoustic advisor that recalls the attention of the user.
Timers have no effect on the heating elements.
Cooking zones must always be stopped manually by rotating the knob in the corresponding [OFF] position.

It's possible to set the timer from 1 to 9h59 minutes: it beeps when the time has run out. This function is always available and is indicated by the clock symbol "H" which is located in the middle of cooktop above the power setting displays.

Timer setting

- Push the Timer knob until "H000" appears, the first two digits H0 start to blink, turn the knob left/ right in order to set the timer value (Hour), press the knob again to set the minutes following the same procedure, confirm the timer value by pressing the knob.
- Pushing the knob before the time is expired is possible pause it (P is displayed), then restart it by pressing the knob again.
- To delate the timer setting keep pressed the knob for about 3 second until the display value disappears.

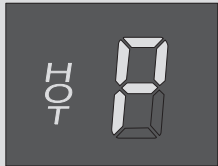
Control knobs and power level adjusting

The placement of each knob corresponds to the placement of the induction element that it controls.

To turn on any, PUSH and TURN the knob clockwise to the required setting, of the according cooking zone can be increased between a minimum of 1 to a maximum of 9. To reduce the power of the cooking zone again it is necessary to turn the knob anticlockwise.

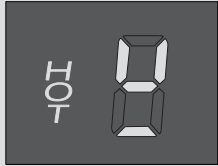
The current power level is displayed on the display unit of the hob.

	<p>Melting function</p> <p>If the knob is turned clockwise from zero position the first "power level" reached is the melting function. The according 7 segment display unit shows this "u" symbol. The melting function is used to heat up the bottom of the pot (40 C inside the pot). This function is used to melt food. The maximum time for using the melting function is limited to 2 hours.</p>
	<p>Warming function</p> <p>The warming function is the second "power level" which will be selected when turning the knob clockwise. The according 7 segment display unit shows this "U" symbol. The warming function is used to heat up the bottom of the pot to 70 C (65 C inside the pot). Using this function the food can be kept warm or it can be used to warm up food gently. The maximum time for using the warming function is limited to 2 hours.</p>
	<p>Automatic Heat Up time function</p> <p>To activate the heat up time automatic press and turn the knob counterwise in overwind position "A" until a beep sounds and the "A" symbol on the display starts blinking waiting for an input. Within the next 10s a valid cooking level has to be selected from 1 to 8. This will be the cooking level after a defined time of higher power output at level 9. The 7 segment display alternates between "A" and the selected cooking level. If the knob is turned clockwise by selecting level 0, level 9, (warming, melting) or in any position counterwise the automatic heat up function will be turned off.</p>



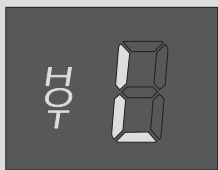
Booster function

To activate the boost function press and turn the knob clockwise in overwind position "P" until a beep sounds. The symbol is as shown "P" and will be displayed. After 10 minutes the boost function will be automatically switched off and the "P" is not shown on the display anymore and the induction control will be set automatically at level 9.



Cookware recognition function

The cooking level of cooking zone can be selected by turning the knob to the according position even if no pot is in place. The output of power starts automatically as soon as an appropriate pot is put on the cooking zone. If no pot is being detected the display changes to the shown "pot missing" symbol after a short time. This symbol will be shown until a appropriate pot is put on the cooking zone or the maximum time of 10 minutes expired. The same applies if the pot is removed during normal cooking. After 10 minutes without detected pot the cooking zone switches off automatically and can only be activated again after returning the knob into the OFF position.

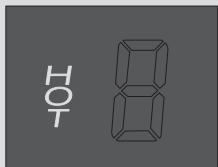


Control Lock function

The control lock is a device that protects the appliance from accidental or inappropriate use. With all cooking zones turned off, simultaneously press and turn the first two left knobs counterwise in overwind position "A". They need to be hold in that position for a least 2s until the symbols "L" appear on the displays, then release the knobs.

In order to deactivate the CL function repeat the same procedure as for activating. After unlocking all knobs have to be turned back in the zero position (if any knob was in a position different from zero). The control is than off and can be operated as expected.

NOTE: If the knobs are not hold in the OWL position for long enough the CL will not be enabled / displayed. If the knobs are hold in that position for more than 30 seconds the input is considered to be invalid and a error message "Permanent use of key" will be displayed (flash symbol).



Residual Heat indication

Cooking zones which are already switched off can still have a hot glass surface. In order to warn and protect users from burning themselves this condition is visualized, the residual heat measurement is done from the temperature sensor of each inductive cooking zone..

When the measured temperature drops below 60 C on the glass the symbol indicating the hot surface disappears.

Some traditional methods of cooking, such as double boiler (bain-marie) for creams, sauces, chocolate, etc. are no longer necessary, because now you can cook these directly in the pan, thanks to perfect power regulation and even temperature distribution of the induction system.

You can use the "Booster" function with water and soups until they boil, then use a lower level immediately to avoid too much steam and to save energy.

When frying heat the oil to the highest power level, then turn down if needed to a medium level when adding food to the pan.

Always use pots and pans with a proper lid.

Reduce the selected power in the cooking area in time, in the case of water do not let it boil unnecessarily for too long.

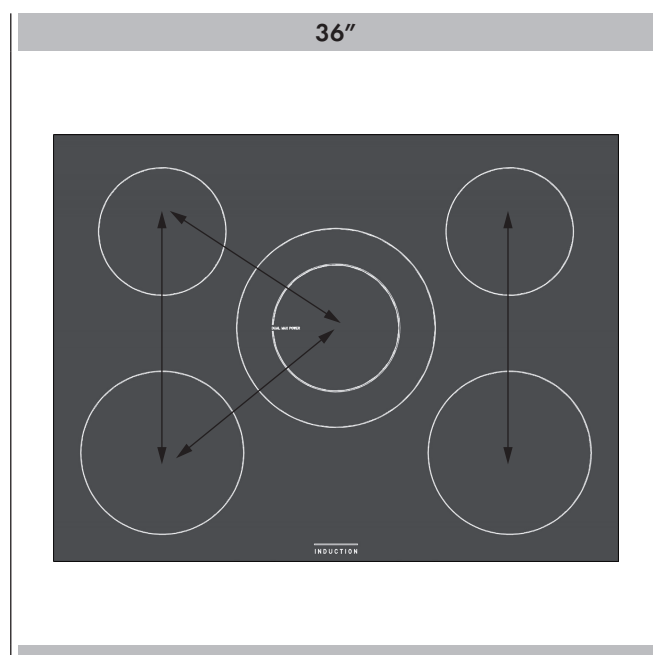
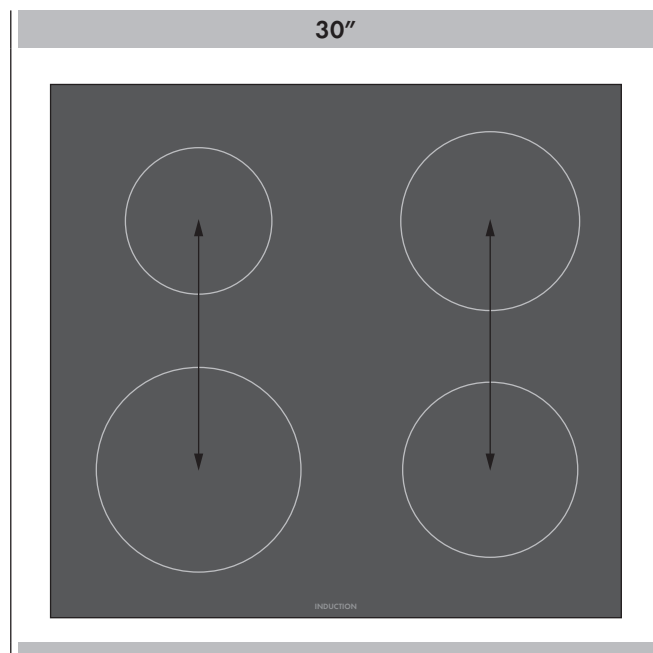
Always choose containers of an adequate size for the amount of food to be cooked. A large pot which is not completely full consumes a lot of energy.

For the best cooking results, metal pots and pans with a flat bottom are recommended. Make sure the bottom of the pan corresponds with the cooking area indicated on the glass.

To save energy cook vegetables and potatoes in a small amount of water. Do not heat empty pans otherwise they may be damaged and can also ruin the glass cooking area.

Before using the cooktop for the first time

- All products are wiped clean with solvents at the factory to remove any visible signs of dirt, oil, and grease which may have remained from the manufacturing process.
- Clean your glass top before the first time you use it. A thorough cleaning with a glass top cleaner is recommended. It only takes a minute and puts a clean, shiny coating on the glass top before its initial use.
- There may be a slight odour during the first several uses: this is normal and will disappear.



- Optimum cooking result depends on the proper cookware being selected and used.
- The cooking surface will hold the heat and remain hot over 20 minutes after the elements have been turned off.
- The glass ceramic cooking surface is a durable material resistant to impact but not unbreakable if a pan or other object is dropped on it.
- Do not allow pans to boil dry. This can damage the pan, element and /or cooktop.
- Do not slide cookware across cooking surface it may scratch the glass

Power Sharing

One generator controls 2 elements, or two cooking zones within a heating section share the power of one generator. Power Sharing is activated when both elements in the same cooking zone are activated and one element is set for Boost (P). The element that is not set for Boost will change to a lower power level. This is called Power Sharing: The latest set cooking level has priority.



IMPORTANT

Automatic Switch OFF

The induction hob has an automatic device which limits the duration of use.

Depending on the chosen cooking level a maximum operation time limitation is defined, the safety device will be activated only if no change of cooking level is done. If this maximum operating time is exceeded on a cooking zone this cooking zone is being switched off, a short beep sounds and if the zone is hot the "residual heat" symbol is showed. In order to reactivate this cooking zone the control knob has to be turned back into OFF position.

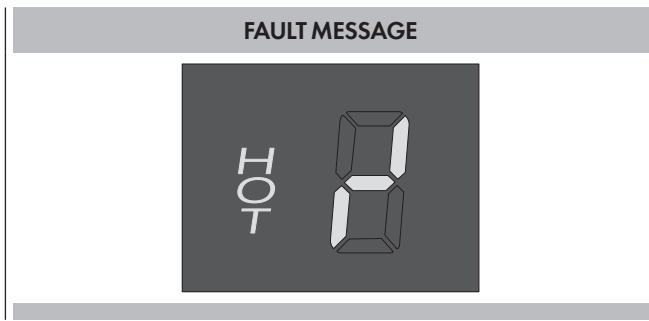


IMPORTANT

Overheating status of cooking zone

If the hob is used on full power for a long period, the electronics could have trouble cooling down if the room temperature is high. To avoid excessively high temperatures forming in the electronics, the power to the cooking zone is managed automatically to protect itself.

Permanent use of keys



If the knobs have been kept rotated in the "A" or "P" positions for more than 30 seconds a fault message will appear on the display.

Cookware "noise"

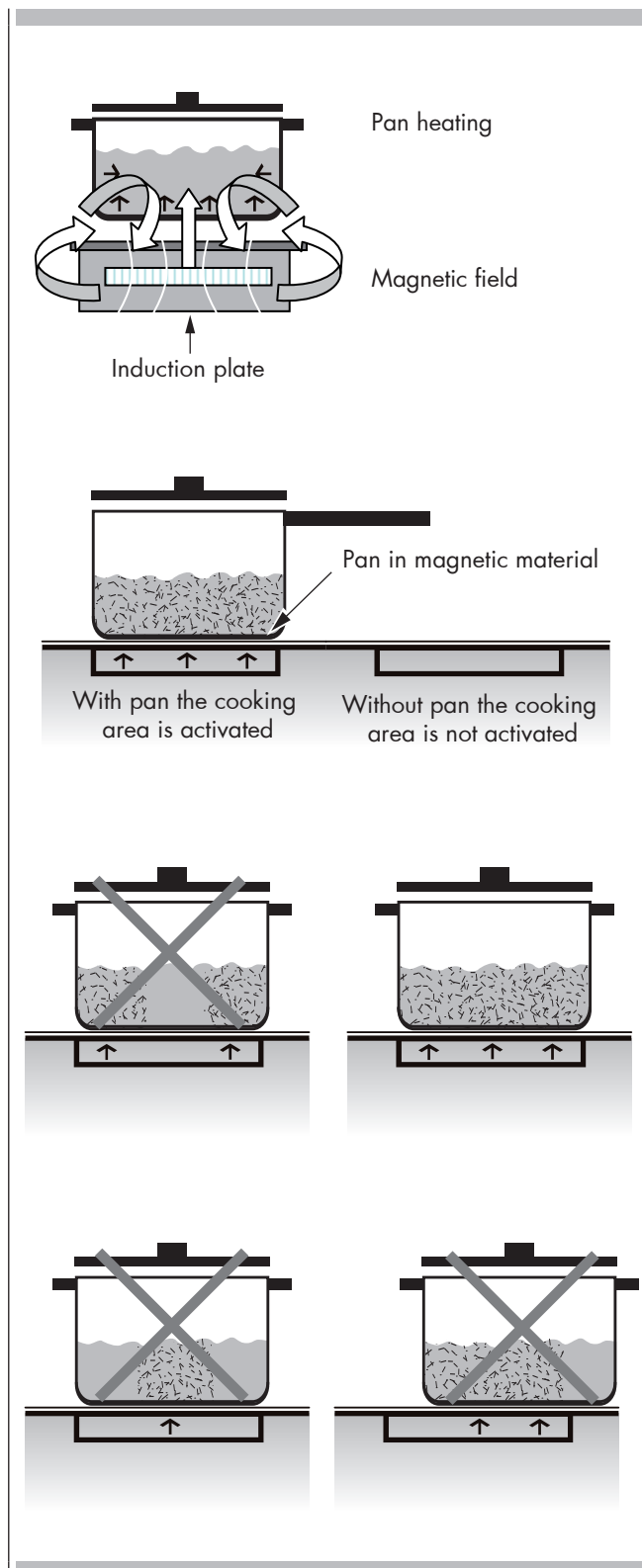
When using adjacent elements that are set at certain power level settings, magnetic fields may interact and produce a low whistle or intermitted "hum". Pans that completely cover the element ring will produce less noise. A low "humming" noise is normal particularly on high settings. These noise can be reduced or eliminated by lowering or raising the power level settings of one or both of the elements.

How INDUCTION heating works

There is an electronic circuit inside the induction hob which powers and commands a coil. This creates a magnetic field which activates when it comes into contact with suitable pots and pans (**magnetic material**).

The pan on the hob warms up instantly, while the hob remains cold.

There is no loss of heat. The heat generated in the pan lets you cook quickly, saving time and energy.



Pots and pans and how to use them

⚠ ATTENTION

There is an electronic circuit inside the induction hob must be made of ferromagnetic material. They can be made of enameled steel, cast iron or special pans of stainless steel for induction.

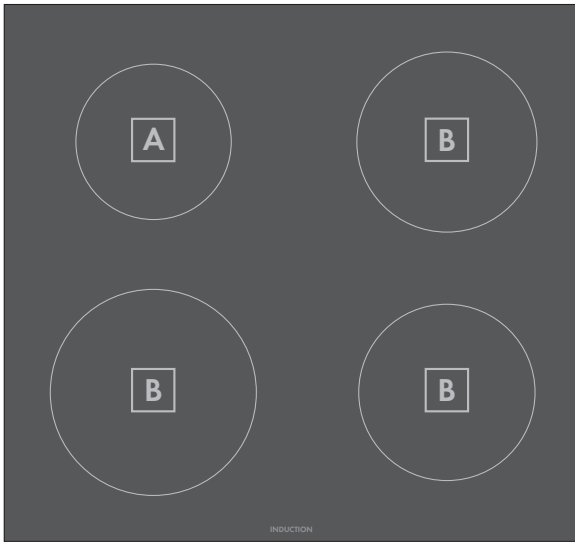
To make sure a pan is suitable, try using a magnet to see if it sticks to the bottom of the pan. Never use normal thin steel nor anything containing even just an amount of glass, terracotta, copper or aluminum.

The display of the cooking area will show if the pan is suitable, if the power indicator flashes the pan is not suitable or the diameter of the bottom is too small for the diameter of the cooking area.

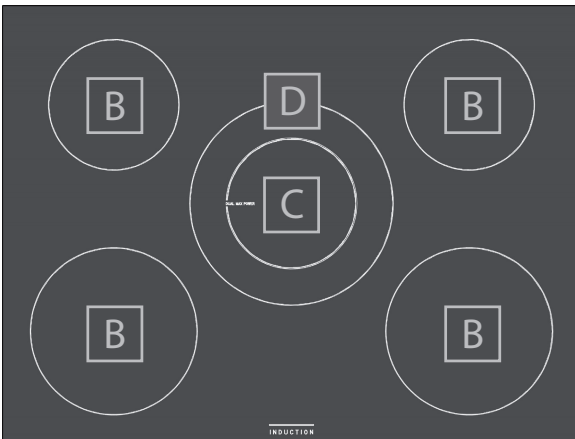
The pots and pans must be placed precisely in the middle of the cooking area.

In some cooking areas an internal diameter is indicated, with a lighter outline.

COOKING AREAS 30"



COOKING AREAS 36"



Use the minimum size pan shown for each cooking element.

Diameter pan size

A	3" 3/4 (9.5 cm)	minimum diameter pan size
B	5" 3/4 (14.5 cm)	minimum diameter pan size
C	4" 7/8 (12.5 cm)	minimum diameter pan size
D	9" 7/8 (25.0 cm)	minimum diameter pan size

NOTE: Dual Size Surface Cooking Area (C-D)

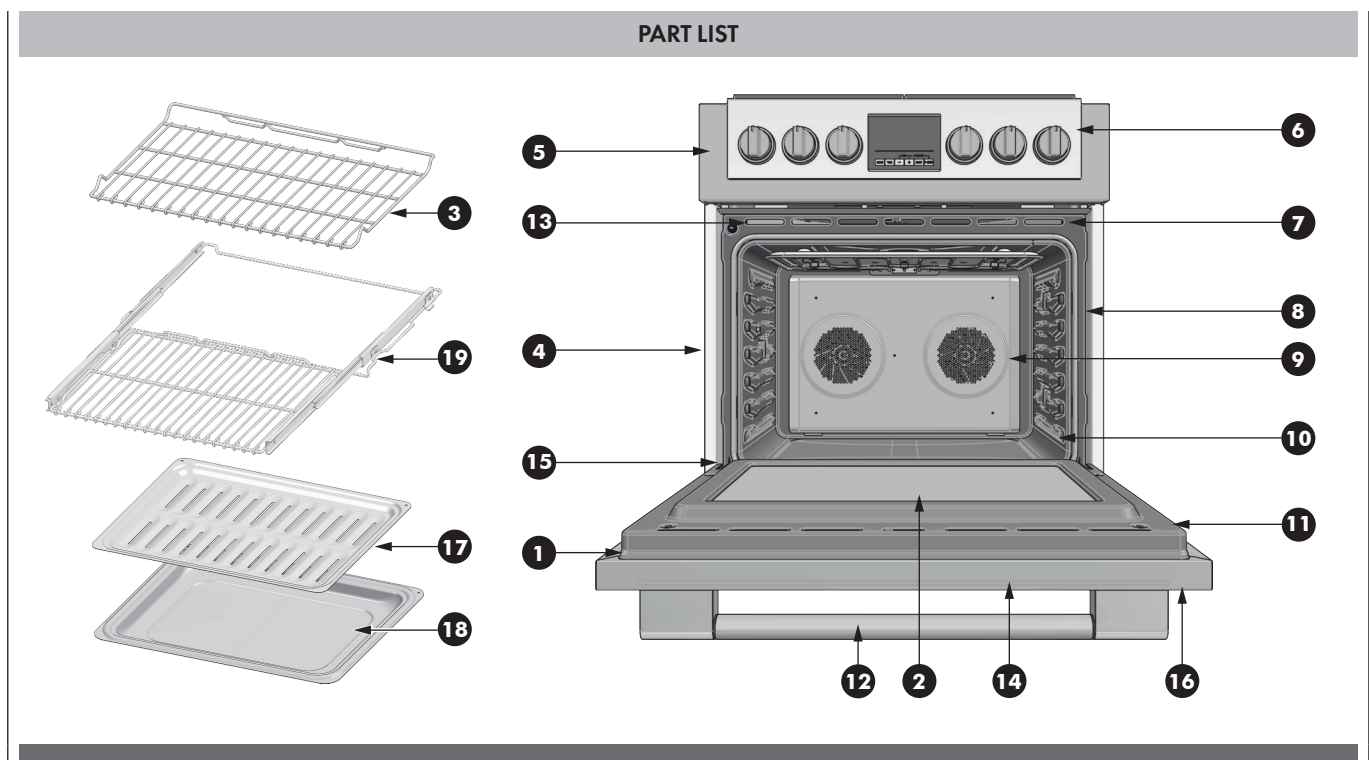
The dual size surface cooking area contains two cooking areas.

If the size of the pan is the same as the single size surface cooking area, the cooking area will work as a single size cooking area.

If the size of the pan is the same as the dual size surface cooking area, the dual size cooking area will activate automatically.

How to Use the Oven Cleaning Chart

1. Locate the number of the part to be cleaned in the illustration on this page.
2. Find the part name in the chart.
 - Use the cleaning method in the left column if the oven has a colored enamel finish.
 - Use the cleaning method in the right column if the oven is stainless steel.
3. Match the letter with the cleaning method on following page.



Cleaning Chart							
Part		Cleaning Method		Part		Cleaning Method	
		Enamelled	Stainless Steel			Enamelled	Stainless Steel
1	Door Frame	D	G	11	Interior Oven Door	E	E
2	Interior Door Windows	F	F	12	Door Handle	G	G
3	Removable Oven Racks	A or E	A or E	13	Door Cooling Vent	E	E
4	Slide Trim	G	G	14	Door Front	C&D	C&G
5	Control Panel Trim	G	G	15	Oven Trim	D	D
6	Control Panel	D	G	16	End Caps	D	G
7	Oven Cooling Vents	D	D	17	Broil Pan Rack	E	E
8	Oven Front Frame	E	E	18	Broil pan Bottom	E	E
9	Oven Cavity	E	E	19	Extendable rack	A	A
10	Mesh Gasket	B	B				

The entire oven can be safely cleaned with a soapy sponge, rinsed and dried. If stubborn soil remains, follow the recommended cleaning methods below.

- Always use the mildest cleaner that will do the job.
- Rub metal finishes in the direction of the grain.
- Use clean, soft cloths, sponges or paper towels.
- Rinse thoroughly with a minimum of water so it does not drip into door slots.
- Dry to avoid water marks.

The cleaners listed below indicate types of products to use and are not being endorsed. Use all products according to package directions.

Part		Cleaning Method
A	Chrome Plated	Wash with hot sudsy water. Rinse thoroughly and dry. Or, gently rub with Soft Scrub®, Bon-Ami®, Comet®, Ajax®, Brillo® or S.O.S.® pads as directed. Easy Off® or Dow® Oven Cleaners (cold oven formula) can be used, but may cause darkening and discoloration. Racks may be cleaned in the oven during the self-clean mode. However, chromed racks will lose their shiny finish and permanently change to a metallic gray.
B	Fiberglass Knit	DO NOT HAND CLEAN GASKET.
C	Glass	Spray Windex® or Glass Plus® onto a cloth first then wipe to clean. Use Fantastik® or Formula 409® to remove grease spatters.
D	Painted	Clean with hot sudsy water or apply Fantastik® or Formula 409® first to a clean sponge or paper towel and wipe clean. Avoid using powdered cleansers and steel wool pads.
E	Porcelain	Immediately wipe up acidic spills like fruit juice, milk and tomatoes with a dry towel. Do not use a moistened sponge/towel on hot porcelain. When cool, clean with hot sudsy water or apply Bon-Ami® or Soft Scrub® to a damp sponge. Rinse and dry. For stubborn stains, gently use Brillo® or S.O.S.® pads. It is normal for porcelain to craze (fine lines) with age due to exposure from heat and food soil.
F	Reflective Glass	Clean with hot sudsy water and sponge or plastic scrubber. Rub stubborn stains with vinegar, Windex®, ammonia or Bon-Ami®. DO NOT USE HARSH ABRASIVES.
G	Stainless	Always wipe or rub with grain. Clean with a soapy sponge then rinse and dry. Or, wipe with Fantastik® or Formula 409® sprayed onto a paper towel. Protect and polish with Stainless Steel Magic® and a soft cloth. Remove water spots with a cloth dampened with white vinegar. Use Zud®, Cameo®, Bar Keeper's Friend® or RevereWare Stainless Steel Cleaner®, to remove heat discoloration.
H	Probe (if present)	Clean probe by hand with detergent and hot water. Then rinse and dry. Do not so or clean in dishwasher.

CAUTION

Be sure electrical power is off and all surfaces are cool before cleaning any part of the cooktop.

Apply a small amount of cooktop cleaning specific ceramic crème on a daily basis. this provides a protective film that makes it easy to remove water spots or food splatters. The temperature of the cooking surface reduces the protective qualities of this cleaner.

It must be reapplied before each use. Use a clean cloth and apply cooktop cleaning crème before each use to remove dust or metal marks that can occur on the counter level surface between uses.

FRAME

(Stainless steel models)

Always wipe with the grain when cleaning. For moderate/heavy soil, use BonAmi® or Soft Scrub® (no bleach).

Wipe using a damp sponge or cloth, rinse and dry.

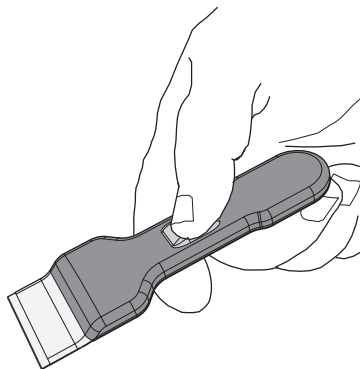
DAILY CLEANING TECHNIQUES

Clean the surface when it is completely cool with the following exception.

CLEANING THE COOKTOP

Remove these soils immediately with the razor blade scraper:

- Dry Sugar
- Sugar Syrup
- Tomato Products
- Milk



USE DAILY

Wipe off splatters with a clean, damp cloth; use white vinegar if smudge remains; rinse.

Apply a small amount of the Cooktop Cleaning Cream.

When dry, buff surface with a clean paper towel or cloth.

CAUTION

Do not use any kind of cleaner on the glass while the surface is hot; use only the razor blade scraper. The resulting fumes can be hazardous to your health. Heating the cleaner can chemically attack and damage the surface.

RECOMMENDED CLEANERS

• **Cooktop Cleaning Crème:**

Use only a small amount; apply to a clean paper towel or cloth. Wipe on the surface and buff with a clean dry towel.

• **BonAmi^{1/2}**

Rinse and dry.

• **Soft Scrub[®] (without bleach):**

Rinse and dry.

• **White Vinegar:**

Rinse and dry.

• **Razor blade scraper**

Packaged with cooktop.

Note: The recommended cleaners indicate a type of cleaner and do not constitute an endorsement.

AVOID THESE CLEANERS

• **Glass cleaners which contain ammoniac or chlorine bleach**

These ingredients may permanently etch or stain the cooktop.

• **Caustic Cleaners**

Oven cleaners such as Easy Off[®] may etch the cooktop surface.

• **Abrasive Cleaners**

Metal scouring pads and scrub sponges such as Scotch Brite[®] can scratch and / or leave metal marks.

Soap-filled scouring pads such as SOS[®] can scratch the surface.

• **Powdery cleaners**

Containing chlorine bleach can permanently stain the cooktop.

• **Flammable cleaners**

Such as lighter fluid or WD-40.

Before contacting service, check the following to avoid unnecessary service charges.

Oven Problem	Problem Solving Steps
Error F1030* or F2030* appears in the display window.	A problem with latch mechanism occurred. Remove power and turn it back on again after a few seconds. The oven should run a latch auto-test. If condition persists, note the code number (in the EVENT LOG list) and contact service.
Other F Error appears in the display window.	Remove power and turn it back on again after a few seconds. If condition persists, note the code number and contact service.
The oven display stays OFF	Turn off power at the main power supply (fuse or breaker box). Turn breaker back on. If condition persists, call an authorized service.
Cooling fan continues to run after oven is turned off	The fan turns off automatically when the electronic components have cooled sufficiently.
Oven door is locked and will not release, even after cooling	Turn the oven off at the circuit breaker and wait a few seconds. Turn breaker back on. The oven should reset itself and will be operable.
Oven is not heating	Check the circuit breaker or fuse box to your house. Make sure there is proper electrical power to the oven. Make sure the oven temperature has been selected.
Oven is not cooking evenly	Check oven calibration. Adjust calibration if necessary (see To Set Temperature, Page 23). Refer to cooking charts for recommended rack position. Always reduce recipe temperature by 25 F (15 C) when baking with Convection Bake mode.
Oven light is not working properly	Replace or reinsert the light bulb if loose or defective. See Page 43. Avoid touching the bulb glass with bare fingers as finger oil may cause bulbs to burn out prematurely.
Oven light stays on	Check for obstruction in oven door. Check to see if hinge is bent or door switch broken.
Oven will not Self-Clean properly	Allow the oven to cool before running Self-Clean. Always wipe out loose soils or heavy spill-over before running Self-Clean. If oven is badly soiled, set oven for a four-hour Self-Clean. See Preparing the Oven to Self-Clean.
Clock and timer are not working properly	Make sure there is proper electrical power to the oven. See the Time sections on Page 23.
Excessive moisture	When using Bake mode, preheat the oven first. Convection Bake and Convection Roast will eliminate any moisture in oven (this is one of the advantages of convection).
Porcelain chips	When oven racks are removed and replaced, always tilt racks upward and do not force them to avoid chipping the porcelain.

Problem	Cause	Possible Remedy
Nothing works	<p>Cooktop not connected to proper electrical circuit.</p> <p>Fuse is blown or circuit breaker is tripped.</p> <p>No electricity to the cooktop.</p> <p>Cooktop is in lockout mode.</p>	<p>Have electrician verify that the proper rated cooktop voltage is being supplied to the cooktop. Have electrician replace fuse or reset circuit breaker.</p> <p>Have electrician check your power supply.</p> <p>Unlock cooktop.</p>
Heating elements do not heat properly	Improper cookware is being used.	Select proper cookware as outlined in the Cooktop Operation section of this manual.
Glass ceramic surface is seethrough or appears to be red in color.	Under direct or bright lighting, you will sometimes be able to see through the glass and into the chassis due to its transparent quality. You may also notice a red tint under these conditions.	These are normal properties of black ceramic glass panels.
Lock Key blocked after first connecting or unresponsive touch control.	When first connecting electrically or after a power failure, any direct strong light over the sensor area may affect the touch control functionality.	When powering on the unit make sure that no strong light is shining direct over the touch control zone, it can promise the start-up sensor calibration resulting in an unresponsive touch control.

With either Bake or Convection Bake, poor results can occur for many reasons other than a malfunction of the oven. Check the chart below for causes of the most common problems. Since the size, shape and material of baking utensils directly affect the baking results, the best solution may be to replace old baking utensils that have darkened and warped with age and use.

BAKING PROBLEM	CAUSE
Food browns unevenly	<ul style="list-style-type: none"> - Oven not preheate - Aluminum foil on oven rack or oven botto - Baking utensil too large for recip - Pans touching each other or oven wall
Food too brown on bottom	<ul style="list-style-type: none"> - Oven not preheate - Using glass, dull or darkened metal pan - Incorrect rack positio - Pans touching each other or oven wall
Food is dry or has shrunk excessively	<ul style="list-style-type: none"> - Oven temperature too lo - Oven not preheate - Oven door opened frequentl - ightly sealed with aluminum foil - Pan size too smal
Food is baking or roasting too slowly	<ul style="list-style-type: none"> - Oven temperature too lo - Oven not preheate - Oven door opened frequentl - ightly sealed with aluminum foil - Pan size too smal
Pie crusts do not brown on bottom or have soggy crust	<ul style="list-style-type: none"> - Baking time not long enoug - Using shiny steel pan - Incorrect rack positio - Oven temperature is too lo
Cakes pale, flat and may not be done inside	<ul style="list-style-type: none"> - Oven temperature too lo - Incorrect baking tim - Cake tested too soo - Oven door opened too ofte - Pan size may be too larg
Cakes high in middle with crack on top	<ul style="list-style-type: none"> - Baking temperature too hig - Baking time too lon - Pans touching each other or oven wall - Incorrect rack positio - Pan size too smal
Pie crust edges too brown	<ul style="list-style-type: none"> - Oven temperature too hig - Edges of crust too thi

Before contacting service, please check "Troubleshooting." It may save you the cost of a service call. If you still need help, follow the instructions below. When calling, please know the purchase date and the complete model and serial number of your appliance. This information will help us to better respond to your request.

Service Data Record

For authorized service or parts information see WARRANTY.

For serial tag location see Page 2. Now is a good time to write this information in the space provided below. Keep your invoice for warranty validation.

Service Data Record
Model Number _____
Serial Number _____
Date of Installation or Occupancy _____

FULGOR MILANO
